



IBRA SHOWERS

2026

COLOR THERAPY

SHOWERS COLLECTION 2026





About Ibra 5

Shower enclosures 12

> **Walk-in** 15

> **Scorrevole** 29
Sliding door
Coulissante

> **Battente** 67
Hinged door
Battante

> **Pivot** 93
Pivot door
Pivotante

> **Pieghevole** 121
Bi-fold door
Pliante

Shower trays 131

Accessories 149

Finishes 161



Arbi nasce nel 1987. Organizzazione, tecnologia e precise logiche di produzione e di gestione hanno consolidato, negli anni, la posizione ed il brand nel mercato di riferimento.

Tradizione e innovazione sono le parole chiave a cui Arbi si ispira quotidianamente: principi cardine di un Know-how frutto dell'esperienza Made in Italy nel settore dei mobili bagno.

Nella vita di un'azienda vi sono dei momenti di svolta, crescita, passaggio al nuovo. In Arbi ciò avviene tutti i giorni, ponendo ricerca, tecnologia ed innovazione sempre come obiettivo primario: lo dimostrano la storia dell'azienda e i programmi per l'immediato futuro. I notevoli investimenti nella ricerca, che caratterizzano da sempre Arbi, sono tangibili nel rapporto qualità prezzo dei prodotti. L'innovazione tecnologica permette di ottimizzare tempi e costi, migliorando gli standard qualitativi.

Arbi was born in 1987. Over the years, the company has solidified its brand and market position through a commitment to organisation, technology and precise production and management strategies. Tradition and innovation are the guiding principles that inspire Arbi every day—core values that define a level of know-how rooted in authentic 'Made in Italy' expertise within the bathroom furniture sector.

In the life of a company, there are moments of change, growth and transition to something new. At Arbi, this evolution happens every day. Research, technology, and innovation remain the primary objectives - as evidenced by the corporate history and vision for the future.

The significant investments in research are tangible in the quality-to-price ratio of the products. Furthermore, technological innovation allows for the optimization of lead times and costs while improving quality standards.

Arbi est née en 1987. Au fil des années, elle a consolidé sa marque sur tous les marchés grâce à son organisation, la technologie impliquée et aux logiques précises de fabrication et de gestion qui régissent l'entreprise. Tradition et innovation sont les mots-clés dont Arbi s'inspire au quotidien : principes clés du savoir-faire qui ont distingué le célèbre Made in Italy dans le secteur du meuble de salle de bain.

Dans la vie de toute entreprise, il y a des moments clés : des tournants, des croissances, des transitions vers le nouveau. Chez Arbi, cela se produit tous les jours : la recherche, la technologie et l'innovation sont les principaux objectifs. Cela a été prouvé par l'histoire de l'entreprise et par ses projets pour l'avenir. Les investissements considérables dans la recherche, qui ont toujours caractérisé Arbi, sont tangibles dans le rapport qualité / prix des produits. L'innovation technologique permet d'optimiser les délais et les coûts, en améliorant les standards de qualité.

Una nuova sfida

L'esperienza maturata nel mondo del mobile ha permesso all'ufficio Ricerca e Sviluppo di costruire nel tempo una profonda conoscenza dei materiali, dall'alluminio al vetro, dall'acciaio inox ad altre soluzioni tecniche che hanno dato forma a un know-how solido fin dalle prime fasi di progettazione. Un patrimonio di competenze che oggi si riflette in ogni dettaglio dei prodotti Ibra Showers.

Il team è composto da figure tecniche e commerciali con una consolidata esperienza nel settore: una competenza maturata sul campo, indispensabile per la progettazione e realizzazione di prodotti complessi come i box doccia.

Ibra Showers si configura come l'elemento che completa l'offerta Arbi, ampliandone le possibilità progettuali. Oggi l'azienda è in grado di proporre un sistema bagno coordinato che comprende mobili, lavabi, vasche, box doccia completi di piatto e termoarredi, offrendo una soluzione armonica e "chiavi in mano". In questo contesto, in linea con i trend di mercato dove il colore è un elemento sempre più richiesto anche nell'ambiente bagno, si inseriscono i profili colorati dei box doccia Ibra, pensati per un concept di bagno "total color", in cui ogni elemento dialoga in modo coerente.

A new challenge

The experience gained in the world of furniture has allowed the Research and Development department to build up a deep knowledge of materials over time, from aluminium to glass, from stainless steel to other technical solutions that have shaped a solid know-how right from the early stages of design. This wealth of expertise is now reflected in every detail of Ibra Showers products. The team consists of technical and commercial professionals with extensive industry experience. This "on-the-ground" expertise is essential for the design and manufacturing of complex products such as shower enclosures.

Ibra Showers completes the Arbi range, expanding its design possibilities. Today, the company is able to offer a coordinated bathroom system—including furniture, washbasins, bathtubs, and shower enclosures complete with trays and heated towel rails—providing a harmonious, "turnkey" solution. In this context, and in line with market trends where color is increasingly sought after element in the bathroom, Ibra Showers' colored profiles are a key feature. They are designed for a "total color" bathroom concept, where every element interacts coherently.

Un nouveau défi

L'expérience acquise dans le monde du mobilier a permis au département Recherche et Développement d'acquérir au fil du temps une connaissance approfondie des matériaux, de l'aluminium au verre, de l'acier inoxydable à d'autres solutions techniques qui ont donné naissance à un savoir-faire solide dès les premières phases de conception. Un patrimoine de compétences qui se reflète aujourd'hui dans chaque détail des produits Ibra Showers. L'équipe est composée de techniciens et de commerciaux ayant une solide expérience dans le secteur : une expertise acquise sur le terrain, indispensable pour la conception et la réalisation de produits complexes tels que les cabines de douche. Ibra Showers complète l'offre Arbi, élargissant ainsi les possibilités de conception. Aujourd'hui, l'entreprise est en mesure de proposer un système de salle de bains coordonné qui comprend des meubles, des lavabos, des baignoires, des cabines de douche avec receveur et des radiateurs sèche-serviettes, offrant une solution harmonieuse et « clé en main ». Dans ce contexte, en phase avec les tendances du marché où la couleur est un élément de plus en plus demandé, même dans la salle de bains, s'inscrivent les profilés colorés des cabines de douche Ibra, conçus pour un concept de salle de bains « total color », où chaque élément dialogue de manière cohérente.

IBRA
SHOWERS





Prodotti di qualità, testati per durare nel tempo

I nostri box doccia rispondono alla normativa UNI EN 14428. Ogni componente è testato per offrire le migliori prestazioni, ben oltre i requisiti previsti dalla normativa. Alluminio, vetro, plastica, acciaio inox sono stati selezionati e utilizzati in base a scelte precise, secondo criteri di durabilità, praticità ed estetica.

I profili verniciati Ibra hanno superato con il massimo risultato la prova di quadrettatura UNI EN ISO 2409:2020, evidenziando l'eccellente tenuta della vernice colorata.

Inoltre, tutti i componenti sono sottoposti a severe prove interne di pulibilità, stabilità, tenuta all'acqua, urto, rottura, usura, cicli di apertura e chiusura, corrosione, resistenza agli agenti chimici e alle macchie, resistenza a cicli umido/secco, garantendo sempre altissimi standard qualitativi.

I piatti doccia soddisfano i requisiti della norma EN 14527:2016 per pulibilità, scarico dell'acqua, scivolosità, resistenza alle sostanze e agli agenti macchianti nonché alle variazioni di temperatura.

Quality products, tested to last

Our shower enclosures comply with UNI EN 14428 standards. Each component is tested to offer the best performance, well beyond the requirements of the standard. Aluminium, glass, plastic and stainless steel have been selected and used based on specific criteria of durability, practicality and aesthetics. Ibra's painted profiles have passed the UNI EN ISO 2409:2020 cross-cut test, demonstrating the exceptional adhesion and endurance of our color finishes. In addition, all components undergo rigorous internal testing for cleanability, stability, water tightness, impact, and breakage. We also test for wear, opening and closing cycles, corrosion, chemical and stain resistance, and wet/dry cycles—consistently guaranteeing the highest quality standards. Our shower trays meet all EN 14527:2016 requirements regarding cleanability, water drainage, slip resistance, and durability against staining agents and thermal fluctuations.

Des produits de qualité, testés pour durer dans le temps

Nos cabines de douche sont conformes à la norme UNI EN 14428. Chaque composant est testé pour offrir les meilleures performances, bien au-delà des exigences prévues par la norme. L'aluminium, le verre, le plastique et l'acier inoxydable ont été sélectionnés et utilisés sur la base de choix précis, selon des critères de durabilité, de praticité et d'esthétique. Les profils peints Ibra ont passé avec brio le test de quadrillage UNI EN ISO 2409:2020, mettant en évidence l'excellente tenue de la peinture colorée. De plus, tous les composants sont soumis à des tests internes rigoureux de nettoyabilité, de stabilité, d'étanchéité, de résistance aux chocs, à la rupture, à l'usure, aux cycles d'ouverture et de fermeture, à la corrosion, aux agents chimiques et aux taches, ainsi qu'aux cycles humide/sec, garantissant ainsi des normes de qualité toujours très élevées. Les receveurs de douche sont conformes aux exigences de la norme EN 14527:2016 en matière de nettoyabilité, d'évacuation de l'eau, de glissance, de résistance aux substances et aux agents tachants ainsi qu'aux variations de température.

Soluzioni su misura

Alcune situazioni o esigenze particolari possono richiedere soluzioni su misura. Le casistiche sono molteplici, possono andare dalle dimensioni non a catalogo, a muretti, spallette e altri elementi che non consentono l'installazione di un prodotto standard.

In questi e altri casi è possibile prevedere soluzioni su misura: i tecnici di Ibra sono a disposizione per studiare ogni caso particolare e proporre soluzioni sartoriali.

Per comunicare la situazione e le dimensioni, è possibile inviare una richiesta utilizzando le schede specifiche predisposte da Ibra Showers.

Customised solutions

Some situations or specific requirements may require customized solutions.

There are many possible scenarios, ranging from non-standard dimensions to walls, pillars, and other elements that do not allow the installation of a standard product.

In these and other cases, customized solutions can be provided: Ibra's technical team is available to study each specific case and propose tailored solutions.

To communicate the situation and dimensions, you can send a request using the specific forms provided by Ibra Showers.

Solutions sur mesure

Certaines situations ou besoins particuliers peuvent nécessiter des solutions sur mesure.

Il existe de nombreux cas. Ils peuvent aller de dimensions hors mesure à d'éléments architecturaux, tel que murs, piliers et d'autres éléments qui ne permettent pas l'installation d'un produit standard.

Dans des cas pareils, il est possible de fournir des solutions spécifiques : les techniciens Ibra sont disponibles pour étudier chaque cas particulier et proposer des options sur mesure.

Pour communiquer votre situation et les dimensions, il est possible d'envoyer une demande en utilisant les formulaires spécifiques préparés par Ibra Showers.



Modulo rilievo
Survey module
Module Revéles



Box doccia / Shower enclosures / Parois de douche

> Walk-in

p. 15 - 27

UNIKO 6-8 mm

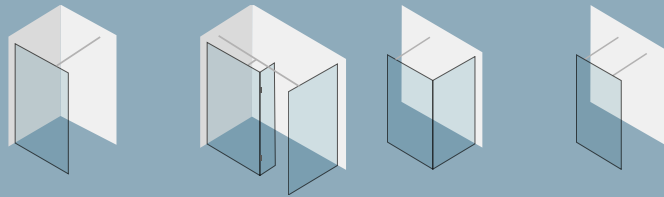

> Scorrevole Sliding door Coulissante

p. 29 - 65

VENTO 8 mm | LEVANTE 6 mm | FIRMA 6 mm

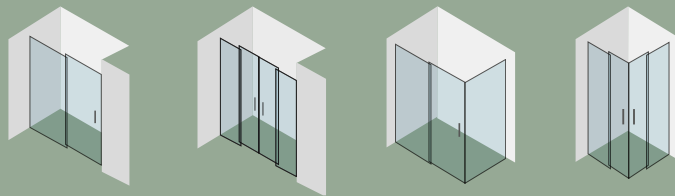

> Battente Hinged door Battante

p. 67 - 91

BEST 6 mm

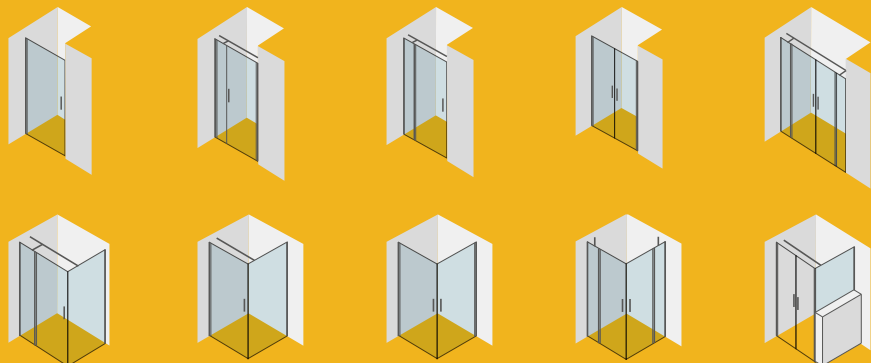

> Pivot Pivot door Pivotante

p. 93 - 119

LODE 6 mm

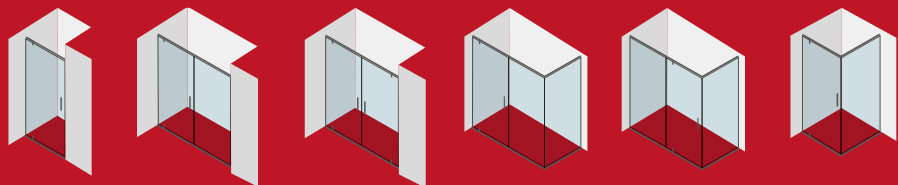

> Pieghevole Bi-fold door Pliante

p. 121 - 129

ZEFIRO / ZEFIRO LIGHT 6 mm

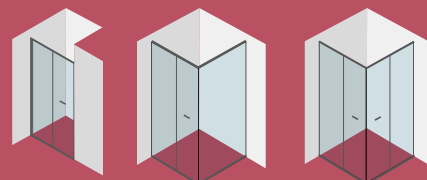

SIPARIO 8 mm

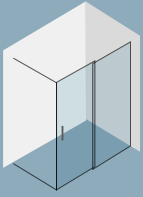

ICON 8 mm | FIRMA 6 mm

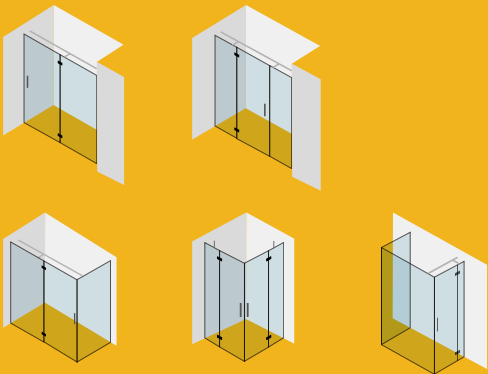

SOPRAVASCA 6 mm

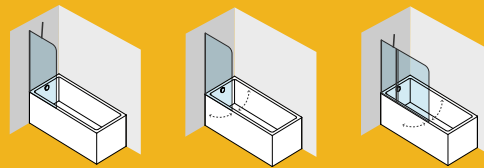

ZEFIRO / ZEFIRO LIGHT 6 mm

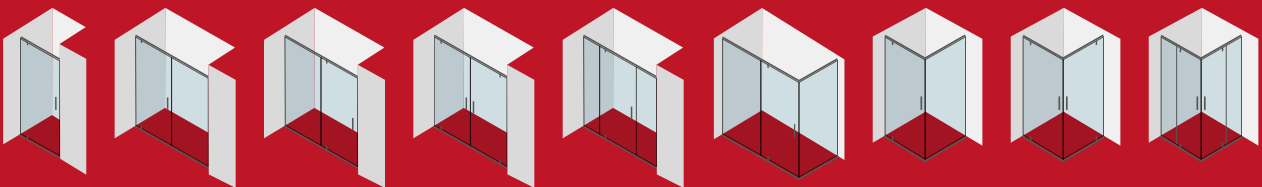

BEST 6 mm

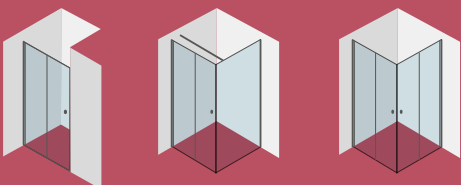

Walk-in

- > 6 - 8 mm
UNIKO 16
- > 8/6 mm
SIPARIO 22

UNIKO



UNIKO

6-8 mm



- > **200 cm altezza standard**
 - > **Reversibile**
 - > **Trattamento vetri anticalcare incluso**
 - > **Stabilizzatore di serie accorciabile in opera**
- > 200 cm standard height
 - > Reversible
 - > Glass anti-scale treatment included
 - > Standard stabilizer adjustable on site
- > Hauteur standard 200 cm
 - > Réversible
 - > Traitement anti-calcaire compris
 - > Stabilisateur de série raccourcissable sur place

Caratterizzata da un design moderno e minimalista, la gamma di stabilizzatori Ibra è studiata per rispondere a esigenze progettuali diverse. Le molteplici configurazioni disponibili, dalla soluzione muro-vetro inclinata a quella a soffitto, garantiscono un'integrazione perfetta in ogni ambiente.

Characterised by a modern, minimalist design, the Ibra range of stabilisers is designed to meet a variety of design requirements. The multiple configurations available, from the inclined wall-glass solution to the ceiling solution, ensure perfect integration into any environment.

Caractérisée par un design moderne et minimaliste, la gamme de stabilisateurs Ibra est conçue pour répondre à différents besoins de conception. Les multiples configurations disponibles, de la solution mur-vitre inclinée à celle au plafond, garantissent une intégration parfaite dans n'importe quel environnement.





UNIKO



Lo stabilizzatore ad angolo disponibile in due misure, è una soluzione funzionale ma di alto valore estetico.

The corner stabiliser, available in two sizes, is a functional solution with high aesthetic value.

Le stabilisateur d'angle, disponible en deux tailles, est une solution fonctionnelle mais très esthétique.



Variante vetro Specchio Cromo, per maggiore privacy.

Specchio Cromo glass variant, for greater privacy.

Variante verre Specchio Cromo, pour plus d'intimité.



In alternativa, il braccetto a soffitto è accorciabile in opera per soddisfare ogni esigenza di installazione.

Alternatively, the ceiling bracket can be shortened on site to suit any installation requirement.

En alternative, le support de plafond peut être raccourci sur place pour répondre à toutes les exigences d'installation.

SIPARIO



SIPARIO

8/6 mm



- | | | |
|---|--|---|
| <ul style="list-style-type: none"> > 200 cm altezza standard > Trattamento vetri anticalcare incluso > Vetro fisso da 8 mm e porta da 6 mm > Sistema soft-close di serie in apertura e chiusura | <ul style="list-style-type: none"> > 200 cm standard height > Glass anti-scale treatment included > 8 mm fixed glass and 6 mm door glass > Opening and closing soft-close system as standard | <ul style="list-style-type: none"> > Hauteur standard 200 cm > Traitement anti-calcaire compris > Verre fixe de 8 mm et porte de 6 mm > système Soft-Close de série en ouvrant et en fermant la porte |
|---|--|---|

Sipario è il nuovo sistema walk-in con anta scorrevole e profilo di contenimento acqua a pavimento.

Sipario is the new walk-in system with sliding door and floor-mounted water containment profile.

Sipario est le nouveau système walk-in avec porte coulissante et profilé de retenue d'eau au sol.



Il profilo di contenimento, laddove superfluo, può essere escluso in opera.

The containment profile, where unnecessary, can be excluded during installation.

Le profilé de retenue, lorsqu'il est superflu, peut être exclu lors de la pose.

Traversa di sostegno in alluminio, regolabile o accorciabile in opera, con sostegno a parete che funge da porta accappatoio.

Aluminium support crossbar, adjustable or shortenable on site, with wall support that acts as a coat rack.

Traverse de soutien en aluminium, réglable ou raccourcissable sur place, avec support mural servant de porte-peignoir.



Presà maniglia ricavata direttamente sull'anta vetro, finemente lavorata.

Handle recessed directly into the glass door, finely crafted.

Poignée encastrée directement dans la porte vitrée, finement travaillée.



Tecnico e funzionale, il profilo reggi traversa con porta accappatoio integrato.

Technical and functional, the crossbar profile with integrated robe hook.

Technique et fonctionnel, le profilé de support transversal avec porte-peignoir intégré.



Scorrevole

Sliding door
Coulissante

> 8 mm	
VENTO	30
> 6 mm	
LEVANTE	42
FIRMA	58

VENTO



VENTO

8 mm



Scorrevole
Sliding door



- > **200 cm altezza standard**
 - > **Trattamento vetri anticalcare incluso**
 - > **Sistema soft-close di serie in apertura e chiusura**
 - > **Regolazione del sistema di scorrimento semplificato**
 - > **Sgancio rapido della porta**
- > 200 cm standard height
 - > Glass anti-scale treatment included
 - > Opening and closing soft-close system as standard
 - > Sliding system simple to set
 - > Door with quick release system
- > Hauteur standard 200 cm
 - > Traitement anti-calcaire compris
 - > Système Soft-Close de série en ouvrant et en fermant la porte
 - > Réglage facile su système de coulissement
 - > Décrochage rapide de la porte





Scorrevole
Sliding door

Soft close di serie in apertura e chiusura, con attuatori a scomparsa.

Opening and closing soft-close system as standard, with retractable actuators.

Système Soft-Close de série en ouvrant et en fermant la porte, avec actionneurs escamotables.



Guarnizione magnetica.

Magnetic gasket.

Joint magnétique



Scorrevole
Sliding door





Scorrevole
Sliding door



Sistema di sgancio rapido della porta scorrevole per facilitare le operazioni di pulizia.

Quick release system for sliding doors to simplify cleaning operations.

Système de décrochage rapide de la porte coulissante pour faciliter les opérations de nettoyage.

**Profilo alluminio
portamagnete con maniglia
integrata a tutta altezza.**

Aluminium profile with
integrated magnet and full
height integrated handle.

Profilé en aluminium avec
aimant intégré et poignée
de la même hauteur.





Scorrevole
Sliding door



**Traversa con taglio a 45°
con giunzione minimale.**

Transversal bar with 45° cut,
to have a minimal junction.

Barre transversale avec
découpe à 45° pour une
jonction minimaliste.



LEVANTE



LEVANTE

6 mm



Scorrevole
Sliding door



- > **200 cm altezza standard**
 - > **Trattamento vetri anticalcare incluso**
 - > **Sistema soft-close di serie in chiusura**
 - > **Installazione vetro senza silicone**
 - > **Sgancio rapido della porta**
- > 200 cm standard height
 - > Glass anti-scale treatment included
 - > Closing soft-close system as standard
 - > Silicone-free glass installation
 - > Door with quick release system
- > Hauteur standard 200 cm
 - > Traitement anti-calcaire compris
 - > Système Soft-Close de série en fermant la porte
 - > Installation du verre sans silicone
 - > Décrochage rapide de la porte





Scorrevole
Sliding door



Traversa di dimensioni ridotte: 3 cm come lo spessore del profilo a muro per un'estetica minimale.

Small crossbar:
3 cm like the thickness of the wall profile for minimalist aesthetics.

Petite barre transversale:
3 cm comme l'épaisseur du profilé mural pour une esthétique minimaliste.



Tappi coprivite a filo con il profilo.

Screw caps flush with the profile.

Capuchons de vis affleurant le profilé.

All'interno del profilo barriera inferiore e del profilo superiore è inserita una guarnizione che facilita l'installazione del vetro senza l'utilizzo di silicone.

On the inside of the upper profile and the lower barrier profile is a seal that facilitates the installation of the glass, without the use of silicone on the outside.

L'intérieur du profilé supérieur et inférieur de la barrière est doté d'un joint qui facilite l'installation du verre, sans qu'il soit nécessaire d'utiliser du silicone à l'extérieur.

Maniglia integrata nel profilo, pratica e minimale allo stesso tempo.

Handle integrated in the profile, practical and minimalist at the same time.

Poignée intégrée au profilé, pratique et minimaliste.





Scorrevole
Sliding door

LEVANTE



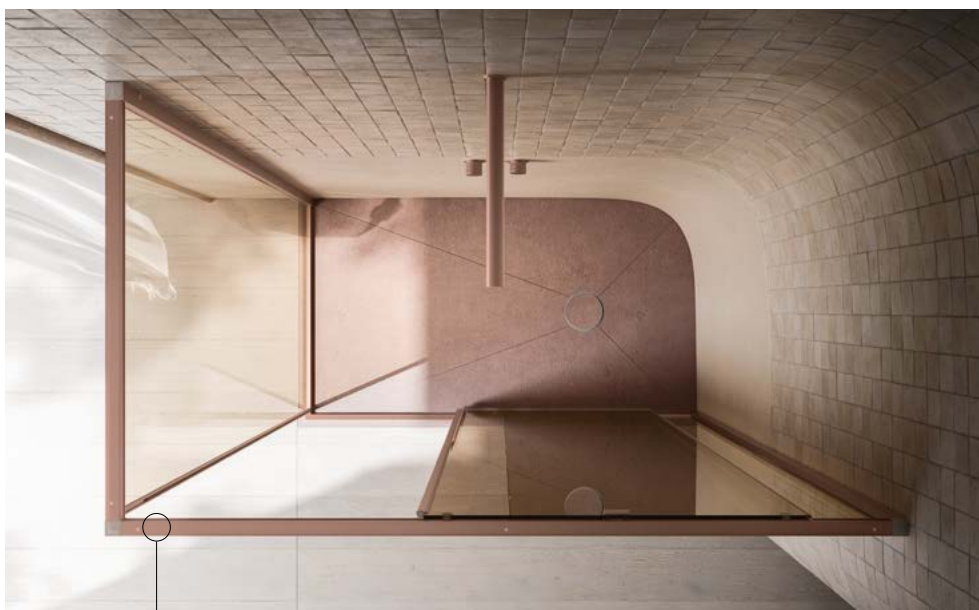

**Carter di chiusura profilo traversa
per una giunzione minimale.**

Crossbar cover caps to have a
minimal junction.

Capuchons de barre transversale
pour une jonction minimaliste.

**Profilo portamagnete di
battuta con guarnizione.**

Magnet holder profile
with gasket.

Profilé porte-aimant
avec joint.

**Il profilo inferiore è continuo,
finemente raccordato da giunti
minimali in alluminio.**

The lower profile is continuous,
finely connected by minimal
aluminium joints.

Le profilé inférieur est continu,
finement relié par des joints
minimaux en aluminium.





**Viti di unione nascoste
a filo o all'interno della
traversa.**

Concealed connecting
screws flush or inside the
crossbar.

Vis de fixation dissimulées
à fleur ou à l'intérieur de la
traverse.







Scorrevoile
Sliding door



Sistema di sgancio rapido della porta scorrevole per facilitare le operazioni di pulizia.

Quick release system for sliding doors to simplify cleaning operations.

Système de décrochage rapide de la porte coulissante pour faciliter les opérations de nettoyage.



Scorrevole
Sliding door

FIRMA



FIRMA

6 mm



Scorrevole
Sliding door



- > **200 cm altezza standard**
 - > **Trattamento vetri anticalcare incluso**
 - > **Sistema soft-close di serie in apertura e chiusura**
 - > **Regolazione del sistema di scorrimento semplificato**
 - > **Sgancio rapido della porta**
- > 200 cm standard height
 - > Glass anti-scale treatment included
 - > Opening and closing soft-close system as standard
 - > Sliding system simple to set
 - > Door with quick release system
- > Hauteur standard 200 cm
 - > Traitement anti-calcaire compris
 - > Système Soft-Close de série en ouvrant et en fermant la porte
 - > Réglage facile su système de coulissement
 - > Décrochage rapide de la porte





Scorrevole
Sliding door

FIRMA



La traversa vista dall'interno del box: pensata per poter togliere facilmente la porta e agevolare le operazioni di pulizia.

The crossbar seen from the inside: conceived to present an elegant solution and for easiness of cleaning.

La barre transversale vue de l'intérieur de la cabine de douche: elle est conçue pour présenter des lignes élégantes et pour permettre un nettoyage facile.



Scorrevole
Sliding door

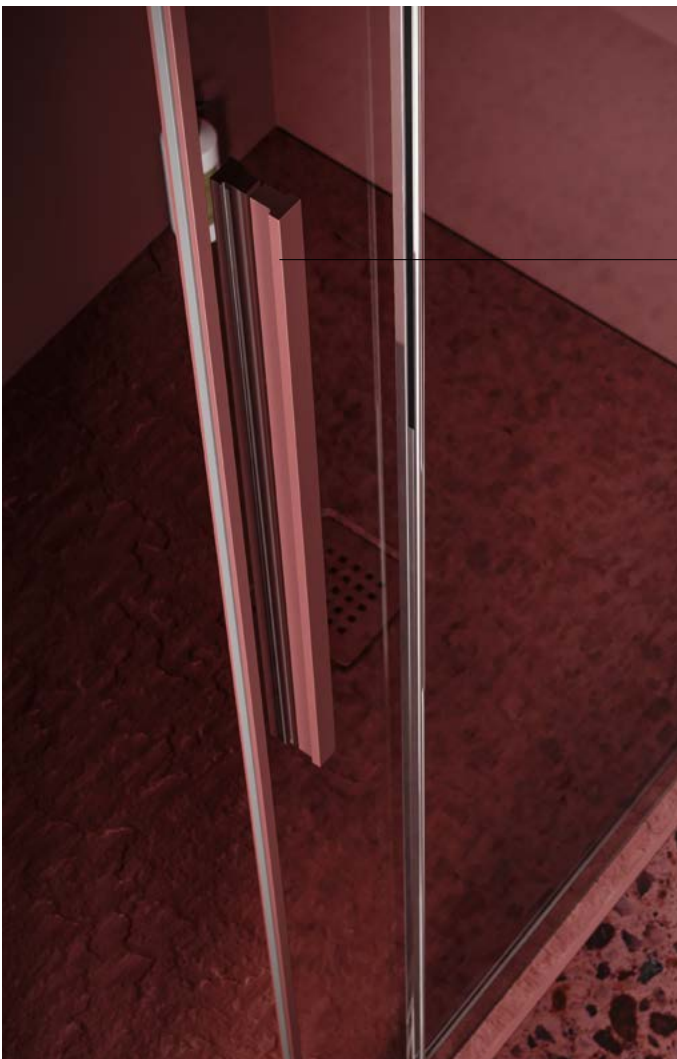

**Maniglia Ti:
un'alternativa lineare
alla maniglia di serie.**

Ti handle: a linear
alternative to the
standard handle.

Poignée Ti: une
alternative linéaire à la
poignée de série.

La sezione ridotta del profilo conferisce leggerezza.

The thin profile gives lightness to the structure.

Le profilé fin donne une légèreté à la paroi.



Sistema di sgancio rapido della porta scorrevole per facilitare le operazioni di pulizia.

Quick release system for sliding doors to simplify cleaning operations.

Système de décrochage rapide de la porte coulissante pour faciliter les opérations de nettoyage.



Scorrevole
Sliding door

ICON



ICON

8 mm



Battente
Hinged door



- > **200 cm altezza standard**
 - > **Trattamento vetri anticalcare incluso**
 - > **Porta con apertura In/Out**
 - > **Sistema di sollevamento della porta in apertura**
- > 200 cm standard height
 - > Glass anti-scale treatment included
 - > Door with In/Out opening
 - > Door lifting system when opening
- > Hauteur standard 200 cm
 - > Traitement anti-calcaire compris
 - > Porte avec ouverture In/Out
 - > Système de levage de la porte à l'ouverture



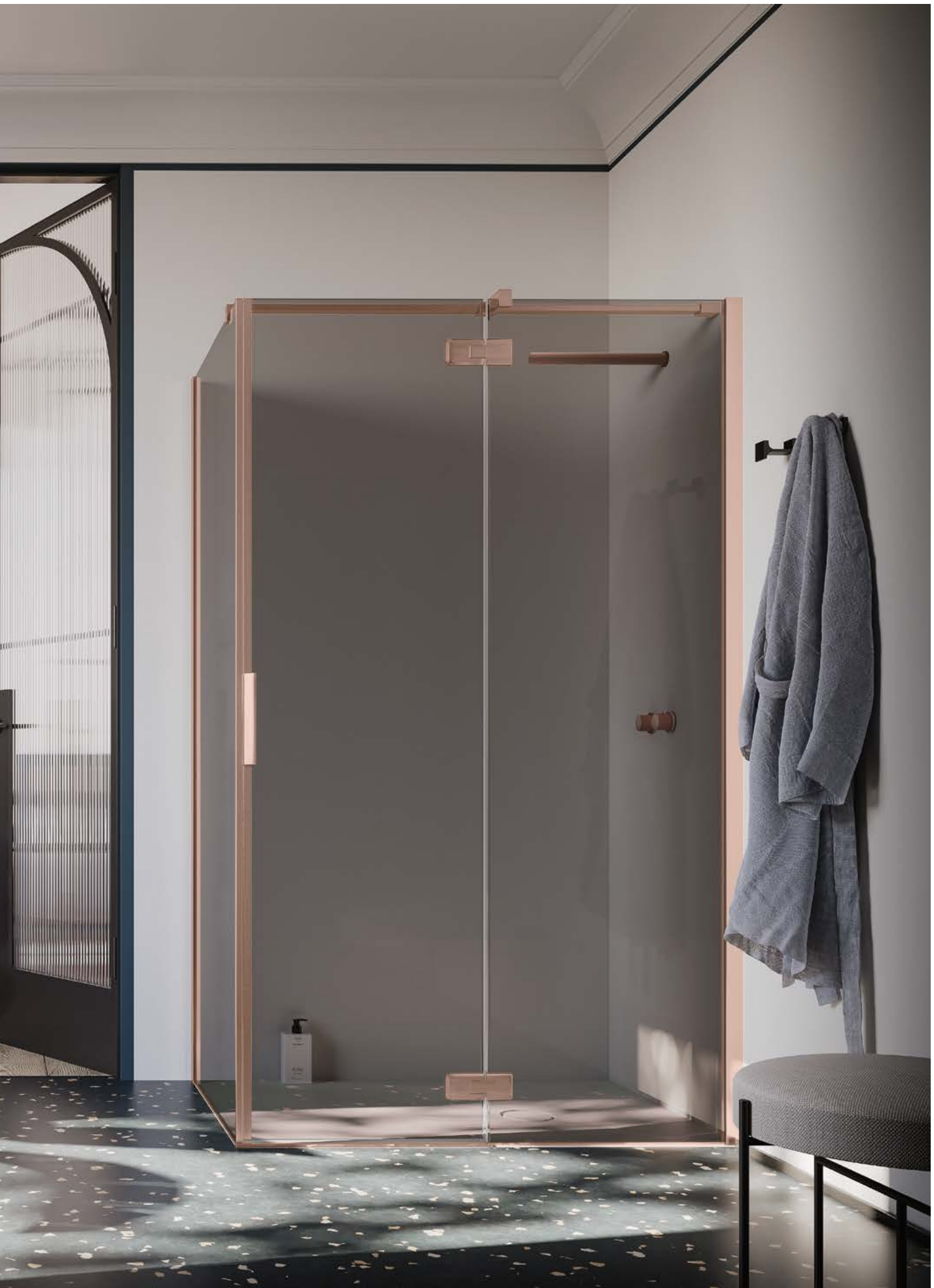

Battente
Hinged door



**Stabilizzatore
inclinato muro-vetro.**

Inclined wall-glass
stabiliser.

Stabilisateur incliné
mur-vitre.

**Apertura in/out per la
massima praticità.
Tappi coprivite in tinta
per un fissaggio a
scomparsa.**

In/out opening for the
best confort. Matching
screw caps.

Ouverture in/out pour
una praticité maximale.
Couvre-vis assorti.





Battente
Hinged door

ICON



ICON Hinged door in niche Nero + Trasparente glass with Fascia serigraphy
LINEAR shower tray Geacril Bianco W 140 x D 80 cm



Tenuta all'acqua ottimale grazie alla guarnizione con salvagoccia.

High watertightness performance thanks to the drip gasket.

Excellente tenue de l'eau grâce au joint contre l'éclaboussement.

Battente
Hinged door

Maniglia "Ti" a vetro come alternativa alla maniglia di serie.

Glass-mounted "Ti" handle as an alternative to the standard handle.

Poignée "Ti" fixée au verre alternative à la poignée de série.



Cerniere Ibra dal design esclusivo, con apertura in-out e sollevamento dell'anta in apertura.

Exclusively designed Ibra hinges, with in-out opening and door lifting upon opening.

Charnières Ibra au design exclusif, avec ouverture in-out et soulèvement du vantail à l'ouverture.





Battente
Hinged door

FIRMA

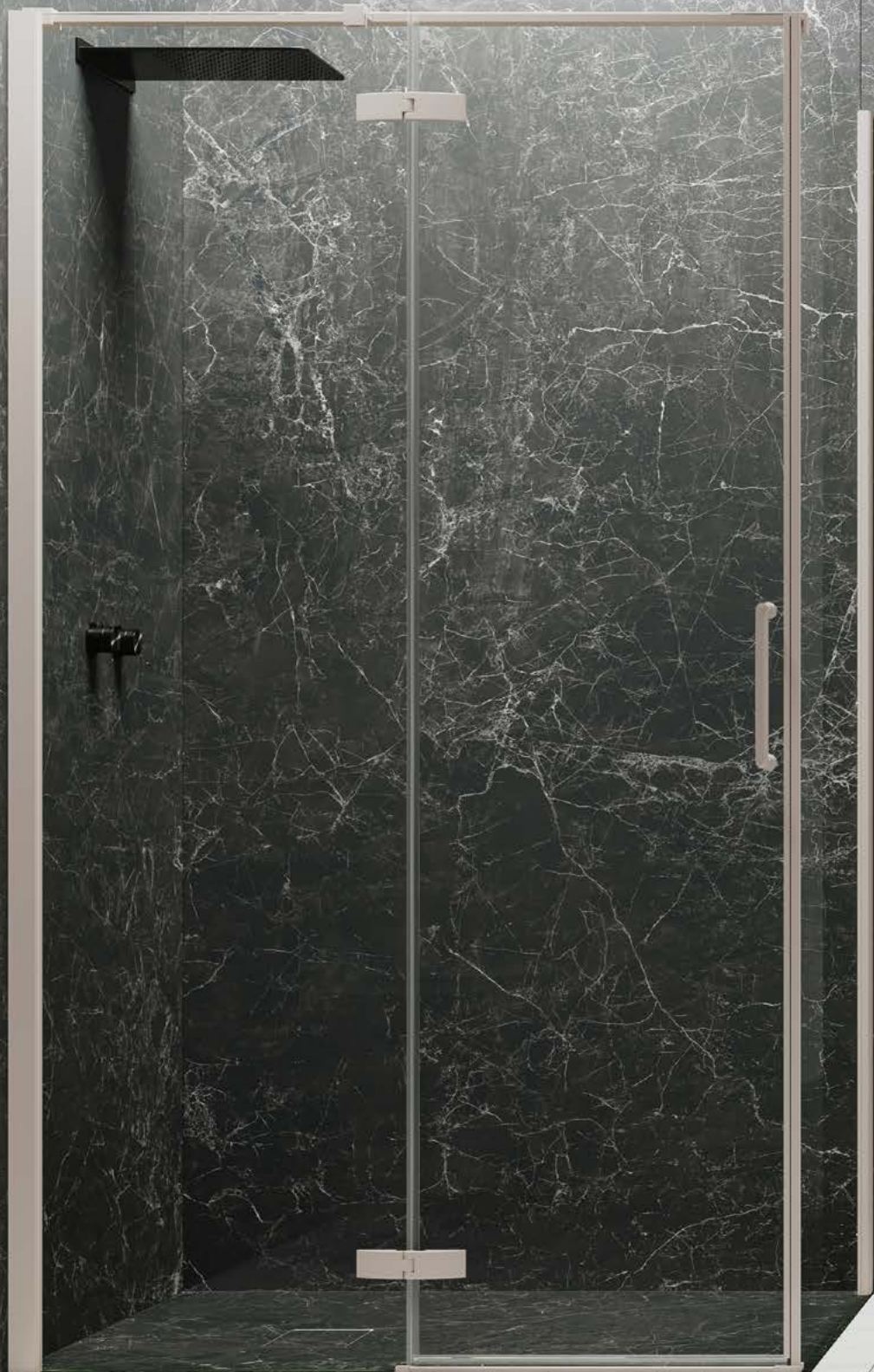

FIRMA

6 mm



Battente
Hinged door



- > **200 cm altezza standard**
- > **Trattamento vetri anticalcare incluso**
- > **Stabilizzatore di serie accorciabile in opera**
- > 200 cm standard height
- > Glass anti-scale treatment included
- > Standard stabilizer adjustable on site
- > Hauteur standard 200 cm
- > Traitement anti-calcaire compris
- > Stabilisateur de série raccourcissable sur place

Maniglia a ponte
Firma di serie.

Firma bridge shaped
handle as standard.

Poignée à pont
Firma de série.





Battente
Hinged door

BEST

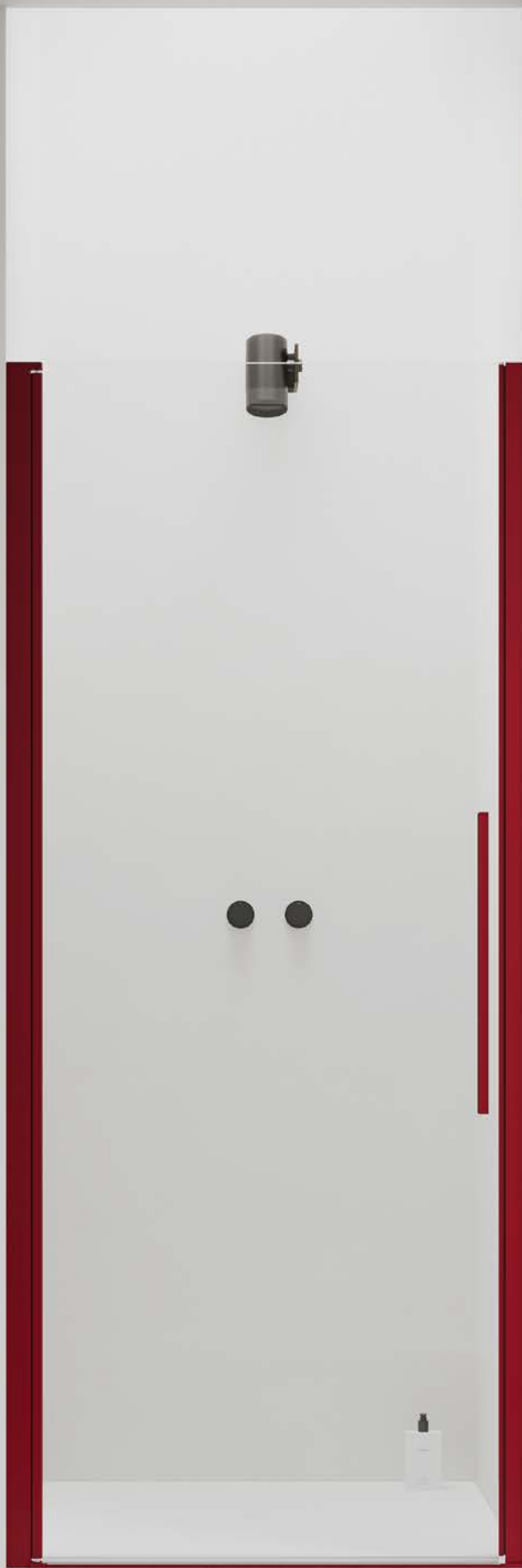

BEST

6 mm



Battente
Hinged door



- > **200 cm altezza standard**
- > **Trattamento vetri anticalcare incluso**
- > **Porta con apertura In/Out**
- > **Sistema di sollevamento della porta in apertura**
- > 200 cm standard height
- > Glass anti-scale treatment included
- > Door with In/Out opening
- > Door lifting system when opening
- > Hauteur standard 200 cm
- > Traitement anti-calcaire compris
- > Porte avec ouverture In/Out
- > Système de levage de la porte à l'ouverture

Camma di sollevamento: per un'apertura fluida anche con piatti a filo pavimento.

Lifting mechanism: for a fluid opening even with shower tray flush to the floor.

Mécanisme de relèvement: pour une ouverture fluide, même en présence d'un receveur au ras du sol.

BEST



Cerniera a tutta altezza consente di aprire la porta verso l'interno e l'esterno.

Hinge integrated in the vertical profile: in/out opening.

Charnière intégrée dans le profile vertical: ouverture in/out.



Battente
Hinged door

BEST



**Apertura a 180°
per una totale
accessibilità.**

180° opening:
for a full accessibility.

Ouverture à 180°:
pour un passage optimal.



Battente
Hinged door



SOPRAVASCA

ON BATHTUB SURBAIGNOIRE

6 mm



Battente
Hinged door



- > 140 cm altezza standard
- > 140 cm standard height
- > Hauteur standard 140 cm
- > **Trattamento vetri anticalcare incluso**
- > Glass anti-scale treatment included
- > Traitement anti-calcaire compris
- > **Sistema di sollevamento della porta in apertura**
- > Door lifting system when opening
- > Système de levage de la porte à l'ouverture

Cerniera continua per un movimento preciso che consente l'apertura verso l'interno e l'esterno. Con sistema di sollevamento della porta in apertura.

Continuous hinge for precise movement that allows inward and outward opening. With door lifting system when opening.

Charnière continue pour un mouvement précis permettant l'ouverture vers l'intérieur et l'extérieur. Avec système de levage de la porte à l'ouverture.

Stabilizzatore inclinato compreso nel prezzo.

Stabilizing bar for 45° application included.

Barre de stabilisation pour application à 45° incluse.





Battente
Hinged door

Pivot

Pivot door
Pivotante

> 6 mm	
ZEFIRO	94
ZEFIRO LIGHT	104
LODE	112

ZEFIRO



ZEFIRO

6 mm



Pivot
Pivot door



- > **200 cm altezza standard**
 - > **Reversibile**
 - > **Trattamento vetri anticalcare incluso**
 - > **Traversa di dimensioni ridotte (2 cm)**
 - > **Installazione vetro senza silicone**
- > 200 cm standard height
 - > Reversible
 - > Glass anti-scale treatment included
 - > Reduced crossbar dimensions (2 cm)
 - > Silicone-free glass installation
- > Hauteur standard 200 cm
 - > Réversible
 - > Traitement anti-calcaire compris
 - > Barre transversale avec dimensions réduites (2 cm)
 - > Installation du verre sans silicone

ZEFIRO





Design deciso e minimalista, ammorbidito dalla lieve smussatura orizzontale donano un tocco di eleganza e raffinatezza alla cerniera Zefiro.

A bold, minimalist design, softened by a slight horizontal bevel, gives the Zefiro hinge a touch of elegance and refinement.

Son design affirmé et minimaliste, adouci par un léger biseautage horizontal, confère une touche d'élégance et de raffinement à la charnière Zefiro.

La guarnizione della cerniera, assicura una barriera alla penetrazione o fuoriuscita dell'acqua. La porta vetro è fissata alla cerniera per mezzo di giunti eccentrici per permettere con semplicità una completa regolazione.

The hinge seal acts as a barrier against water penetration or leakage. The glass door is fixed to the hinge by means of eccentric joints to allow for easy and complete adjustment.

Le joint de la charnière assure une barrière contre la pénétration ou les fuites d'eau. La porte vitrée est fixée à la charnière à l'aide de joints excentriques afin de permettre un réglage complet en toute simplicité.



Maniglione Zefiro, realizzato in alluminio ad effetto cannettato, fissato per mezzo di supporti finemente curati e raccordati, per un design elegante e funzionale.

Zefiro handle, made of aluminium with a ribbed effect, fixed by means of finely crafted and connected supports, for an elegant and functional design.

Poignée Zefiro, réalisée en aluminium à effet cannelé, fixée à l'aide de supports soigneusement travaillés et raccordés, pour un design élégant et fonctionnel.





Pivot
Pivot door

ZEFIRO



Esperienza progettuale e conoscenza delle materie prime, hanno permesso la realizzazione di una traversa stabile ma di ingombro ridotto per un'estetica che sicuramente affascina nella sua versatilità.

Design experience and knowledge of raw materials have enabled the creation of a stable yet compact crossbar with an aesthetic that is sure to appeal thanks to its versatility.

L'expérience en matière de conception et la connaissance des matières premières ont permis la réalisation d'une traverse stable mais peu encombrante, pour un résultat esthétique qui séduit par sa polyvalence.





Anche le parti non a vista sono curate e rifinite nei minimi dettagli.

Even the parts that are not visible are carefully crafted and finished down to the smallest detail.

Même les parties non visibles sont soignées et finies dans les moindres détails.

Profilo di contenimento a pavimento, a sezione esclusiva con presenza di diga di contenimento. Un rilievo superiore di ulteriore barriera all'acqua.

Floor containment profile, with an exclusive section featuring a containment dam. An upper relief providing an additional water barrier.

Profilé de confinement au sol, à section exclusive avec présence d'une digue de confinement. Une relief supérieur constitue une barrière supplémentaire contre l'eau.





Pivot
Pivot door

ZEFIRO LIGHT



ZEFIRO LIGHT

6 mm



Pivot
Pivot door



- > 200 cm altezza standard
- > Nessuna traversa superiore per un'estetica più leggera
- > Trattamento vetri anticalcare incluso
- > Installazione vetro senza silicone
- > 200 cm standard height
- > No upper crossbar for a lighter look
- > Glass anti-scale treatment included
- > Silicone-free glass installation
- > Hauteur standard 200 cm
- > Pas de traverse supérieure pour un design plus épuré
- > Traitement anti-calcaire compris
- > Installation du verre sans silicone

L'attenzione alla funzione di barriera all'acqua è massima nell'ambiente doccia e lo dimostra lo studio progettuale del raccordo angolare nella soluzione a doppia anta ad angolo: un raccordo con vasca di raccolta acqua e invaso di scolo per rallentare, raccogliere e far defluire l'acqua verso il piatto doccia.

The focus on water barrier functionality is paramount in the shower environment, as demonstrated by the design of the corner connection in the double corner door solution: a connection with a water collection tray and drainage basin to slow down, collect and drain water towards the shower tray.

L'attention portée à la fonction de barrière contre l'eau est maximale dans l'environnement de la douche, comme le démontre l'étude de conception du raccord d'angle dans la solution à double porte d'angle : un raccord avec bac de récupération d'eau et réservoir d'évacuation pour ralentir, recueillir et évacuer l'eau vers le receveur de douche.





Pivot
Pivot door



**Maniglione Zefiro laccato opaco,
in tinta con i profili.**

Zefiro matt lacquered handle,
matching the profiles.

Poignée Zefiro laquée mate,
assortie aux profilés.



ZEFIRO LIGHT





Stabilizzatore con braccetto in alluminio accorciabile in opera.

Stabiliser with aluminium bracket that can be shortened during installation.

Stabilisateur avec support en aluminium raccourcissable sur place.

Maniglia Zefiro nel suo caratteristico profilo smussato e curata in ogni dettaglio anche nel lato interno. Arricchita da un pomolo di design minimalista ed ergonomico.

Zefiro handle with its characteristic rounded profile and attention to detail even on the inside. Enhanced by a minimalist and ergonomic knob.

Poignée Zefiro au profilé biseauté caractéristique et soignée dans les moindres détails, même à l'intérieur. Agrémentée d'un bouton au design minimaliste et ergonomique.



LODE



LODE

6 mm



- > 200 cm altezza standard
- > Reversibile
- > Trattamento vetri anticalcare incluso
- > Box doccia intelaiato
- > 200 cm standard height
- > Reversible
- > Glass anti-scale treatment included
- > Framed shower enclosure
- > Hauteur standard 200 cm
- > Réversible
- > Traitement anti-calcaire compris
- > Cabine de douche encadrée

LODE





Pivot
Pivot door



**Apertura pivot con cerniere regolabili;
fissaggio interno a filo vetro.**

Pivot opening with adjustable hinges;
internal fixing flush to the glass.

Ouverture pivot avec charnières réglables;
fixation interne au ras du verre



Pivot
Pivot door







**Cerniera pivot
elegante e minimale,
curata nel dettaglio.**

Elegant and
minimalist pivot
hinge, with attention
to detail.

Charnière pivotante
élégante et
minimaliste, soignée
dans les moindres
détails.



**Guarnizione
magnetica nera.**

Black magnetic
gasket.

Joint magnétique
noir.

Pieghevole

Bi-fold door

Pliante

> 6 mm

ZEFIRO 122

ZEFIRO LIGHT 124

BEST 126

ZEFIRO



ZEFIRO & ZEFIRO LIGHT

6 mm



- > **200 cm altezza standard**
- > **Trattamento vetri anticalcare incluso**
- > **Cerniera di snodo apribile solamente verso l'esterno per facilitare l'apertura dell'anta pieghevole**
- > **Installazione vetro senza silicone**
- > 200 cm standard height
- > Glass anti-scale treatment included
- > Joint hinge that can be opened only outwards to facilitate opening of the folding door
- > Silicone-free glass installation
- > Hauteur standard 200 cm
- > Traitement anti-calcaire compris
- > Charnière de jonction qui ne peut être ouverte que vers l'extérieur pour faciliter l'ouverture de la porte pliante
- > Installation du verre sans silicone

Configurazione ad anta pieghevole, vestita della nuova maniglia Zefiro orizzontale a passo ridotto. Questa soluzione offre una solida impugnatura, di facile accompagnamento in fase di apertura e chiusura dell'anta.

Bi-fold door configuration, fitted with the new Zefiro horizontal handle with reduced pitch. This solution offers a solid grip, making it easy to open and close the door.

Configuration à porte pliante, équipée de la nouvelle poignée Zefiro horizontale à pas réduit. Cette solution offre une prise solide, facile à accompagner lors de l'ouverture et de la fermeture de la porte.





Pieghevole
Bi-fold door

BEST



BEST

6 mm



- > **200 cm altezza standard**
 - > **Trattamento vetri anticalcare incluso**
 - > **Sistema di sollevamento della porta in apertura**
 - > **Stabilizzatore di serie accorciabile in opera**
- > 200 cm standard height
 - > Glass anti-scale treatment included
 - > Door lifting system when opening
 - > Standard stabilizer adjustable on site
- > Hauteur standard 200 cm
 - > Traitement anti-calcaire compris
 - > Système de levage de la porte à l'ouverture
 - > Stabilisateur de série raccourcissable sur place



Cerniera minimale della stessa finitura del box doccia: apertura esterna per facilitare la movimentazione del soffietto.

Minimal hinge matched with the shower enclosure: outwards opening to easier the movement.

Charnière minimaliste assortie au profilé de la parois de douche: ouverture vers l'extérieur pour faciliter le mouvement du soufflet.

L'impacchettamento della porta è totale: ottimo per soluzioni dove gli spazi sono ridotti.

The folding door is the perfect solution where spaces are reduced.

L'empaquetage de la porte est totale: c'est parfait pour des endroits étroits.





Pieghevole
Bi-fold door



Piatti doccia

Shower trays

Receveur de douche

MARK	132
FEEL 2.0	134
LINEAR	136
SYNTHESIS	138
SILK	140
PEGASO	142
AUREO	144

MARK



MARK

Tekno Gelcoat 3 cm



- > **Superficie antibatterica e antiscivolo**
- > **Antigoccia**
- > **Antimacchia**
- > **Antigraffio**
- > **Facilmente tagliabile in opera**

- > Antibacterial and non-slip surface
- > Anti-drip
- > Anti-patches
- > Anti-scratch
- > Easily cut on site

- > Surface anti-bactérienne et antidérapante
- > Hydrofuges
- > Antitâche
- > Anti-rayure
- > Facile à découper sur place

FEEL 2.0



FEEL 2.0

Tekno Gelcoat 2,7 cm



- > **Superficie antibatterica e antiscivolo**
- > **Antigoccia**
- > **Antimacchia**
- > **Antigraffio**

- > Antibacterial and non-slip surface
- > Anti-drip
- > Anti-patches
- > Anti-scratch

- > Surface anti-bactérienne et antidérapante
- > Hydrofuges
- > Antitâche
- > Anti-rayure

LINEAR



LINEAR

Geacril 2,5 cm



> **Superficie antibatterica e antiscivolo**

- > **Antigoccia**
- > **Disponibile nei colori Arbi (esclusi Metal)**
- > **Antigraffio**

> Antibacterial and non-slip surface

- > Anti-drip
- > Available in Arbi colours (except Metal)
- > Anti-scratch

> Surface anti-bactérienne et antidérapante

- > Hydrofuges
- > Disponibles dans les couleurs Arbi (à l'exception des Metal)
- > Anti-rayure



SYNTHESIS

Tekorstone 2 cm



> **Superficie antibatterica e antiscivolo**

- > **Antigoccia**
- > **Disponibile nei colori Arbi (esclusi Metal)**
- > **Antigraffio**

> Antibacterial and non-slip surface

- > Anti-drip
- > Available in Arbi colours (except Metal)
- > Anti-scratch

> Surface anti-bactérienne et antidérapante

- > Hydrofuges
- > Disponibles dans les couleurs Arbi (à l'exception des Metal)
- > Anti-rayure

SILK



SILK

Tekor (solid surface) 2,5 cm



- > Ripristinabile
- > Facile de pulire

- > Restorable
- > Easy to clean

- > Peut être facilement restauré
- > Facile à nettoyer



PEGASO

Laminam/Gres 2,9/3,2 cm



- > **Superficie antibatterica e antiscivolo**
- > **Antigoccia**
- > **Antimacchia**
- > **Antigraffio**

- > Antibacterial and non-slip surface
- > Anti-drip
- > Anti-patches
- > Anti-scratch

- > Surface anti-bactérienne et antidérapante
- > Hydrofuges
- > Antitâche
- > Anti-rayure

AUREO



AUREO

Laminam/Gres 4/4,3 cm



- > **Superficie antibatterica e antiscivolo**
- > **Antigoccia**
- > **Antimacchia**
- > **Antigraffio**

- > Antibacterial and non-slip surface
- > Anti-drip
- > Anti-patches
- > Anti-scratch

- > Surface anti-bactérienne et antidérapante
- > Hydrofuges
- > Antitâche
- > Anti-rayure



**Piatto doccia sartoriale
altamente personalizzabile
e abbinabile con le stesse
finiture Arbi Laminam e Gres**

Tailor made shower tray
highly customizable which can
be matched with the same
Laminam and Gres finishes.

Le receveur de douche sur
mesure est parfait pour être
combiné avec les plans de
toilette assortis en Laminam
et Gres.

**È possibile effettuare con facilità scansi e tagli per
lavorazioni particolari come colonne e pilastri.**

It is possible to make shaping cuts for particular situation
as colums or pillers.

Il est possible de faire des changements et des découpes
spéciales aisément en présence de colonnes ou peliers.

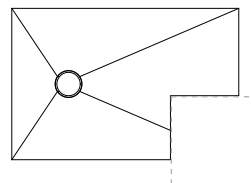
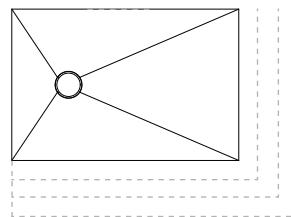



Piatti doccia
Shower trays

Termoarredi

Radiators
Radiateurs

SATIN	150
AUREO	152

Accessori

Accessories
Accessoires

ZEUS	154
CHRONOS	156

SATIN



SATIN

Glass



- > **Spessore vetro: 0,4 cm**
- > **Misure: slim, small e medium**
- > **Telecomando incluso nel prezzo**
- > **Tastiera touch integrata, posizione fissa a dx**
- > Glass thickness: 0,4 cm
- > Sizes: slim, small and medium
- > Remote control included
- > Touch keyboard, positioned on the right
- > Épaisseur verre: 0,4 cm
- > Mesures: slim, small et medium
- > Télécommande incluse
- > Écran tactile, position fixe à droite

AUREO



AUREO

Laminam / Gres



- | | | |
|--|---|--|
| > Finiture Laminam o Gres | > Laminam or Gres finishes | > Finition Laminam ou Gres |
| > Spessore: 0,3 o 0,6 cm | > Thickness: 0.3 or 0.6 cm | > Épaisseur: 0,3 ou 0,6 cm |
| > Misure: slim, small e medium | > Sizes: slim, small and medium | > Mesures : slim, small et medium |
| > Telecomando incluso nel prezzo | > Remote control included | > Télécommande incluse |
| > Tastiera touch nera, posizione fissa a dx | > Black touch keyboard, positioned on the right | > Écran tactile noir, position fixe à droite |

ZEUS



**Appendino e portasalviette
Zeus disponibili in finitura Inox
spazzolato o Nero spazzolato.**

Zeus hook and towel rail available
in brushed Inox or brushed Nero
finish.

Accroche et porte-serviettes Zeus
disponibles en finition Inox brossé
ou Nero brossé.





**Appendino e portasalviette
Chronos disponibile con tondino
pieno interamente in alluminio o
con inserto in Laminam/Gres.**

Chronos hanger and towel-rail
accessories available in fully
aluminium-plated or with insert in
Laminam/Gres.

Chronos crochet et porte-serviette
disponibles avec rondelle en
 finition entièrement plaqués
 aluminium ou avec insert en
 Laminam/Gres.





Accessori Chronos brill con
inserti in Laminam Ardesia
Spacco Bianco

Accessori Chronos brill with
insert in Laminam Ardesia
Spacco Bianco

Accessori Chronos brill avec
insert en Laminam Ardesia
Spacco Bianco



Accessorio per walk-in Uniko e lati fissi di box doccia ad angolo: portasalviette lato esterno e mensola porta oggetti lato interno. Disponibile in Brill o Nero, con tondino in alluminio pieno o con inserto in Laminam/Gres.

Accessory for Uniko walk-in showers and fixed sides of corner shower enclosures: towel rail on the outside and shelf for storing items on the inside. Available in Brill or Nero finish, with solid aluminium rod or Laminam/Gres insert.

Accessoire pour cabines de douche walk-in Uniko et parois fixes de cabines de douche d'angle : porte-serviettes côté extérieur et étagère porte-objets côté intérieur. Disponible en Brill au Nero, avec tige en aluminium massif ou avec insert en Laminam/Grès.

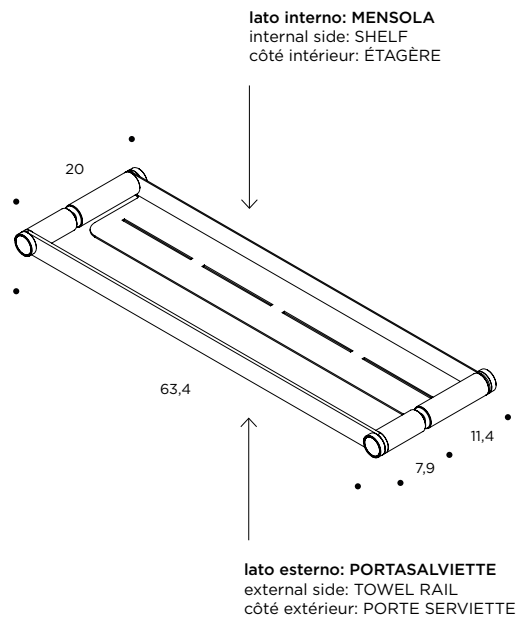

Mensola portaoggetti H 52,7 o 72,2 cm in metallo, disponibile in finitura Bianco o Nero. Posizionabile su vetri spessore 6 e 8 mm.

Metal shelf H 52.7 or 72.2 cm, availables in Bianco or Nero finish. It can be positioned on glass 6 and 8 mm thickness.

Étagère en métal H 52,7 ou 72,2 cm, disponible en finition Bianco ou Nero. Elle est positionnable sur verre ép. 6 et 8 mm.





Finiture

Finishes

Finitions

Profili 162
Profiles
Profils

Vetri 164
Glass
Verres

Serigrafie 164
Serigraphies
Sérigraphies

Piatti doccia 165
Shower trays
Receveurs de
douch

**Per la reale tonalità delle finiture e dei colori,
fare sempre riferimento al campionario.**

For the actual colour and finish shades, please
see the samples.

Pour la réelle tonalité des finitions et des coloris,
se référer à l'échantillonnage.

Profili

Profiles . Profils

Cat. A



B
Brill



N
Nero

Cat. B

Spazzolato
Brushed
Brossé

Esclusi i modelli
Excluded models
Modèles exclus :
> BEST
> LODE
> ZEFIRO
> ZEFIRO LIGHT



X
Inox spazzolato



T
Antracite spazzolato



G
Oro spazzolato



C
Rame spazzolato

Cat. C

Laccato Metal
Metal lacquered
Laqué Metal



M6
Metal Argento



M5
Metal Ghisa



M4
Metal Oro



M8
Metal Rame



M9
Metal Inox

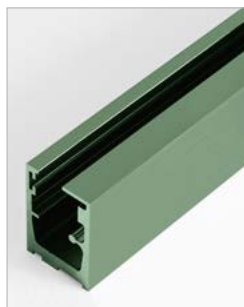

M7
Metal Verde

Cat. C

Laccato opaco
Matt lacquered
Laqué mat



CF
Sambuco



C0
Juta



C3
Burro



C9
Stone



AN
Creta



D3
Tan Pink



C5
Blush



C1
Tè Verde



D8
Verde Oliva



O2
Ceruleo

Cat. D

Laccato opaco
Matt lacquered
Laqué mat



M
Colori Arbi opachi
Arbi matt colors
Couleurs Arbi mats



RAL / NCS
Colore a richiesta
Color on request
Couleur sur demande

Vetri

Glass . Verres

> 6 mm
> 8 mm



00
Trasparente > 8 mm
> 6 mm



SA
Satinato > 8 mm
> 6 mm



GE
Grigio Europa > 8 mm
> 6 mm

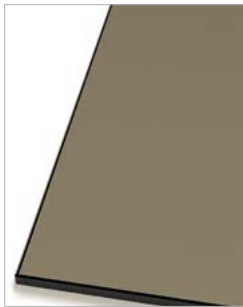

BZ
Bronzo > 8 mm
> 6 mm



CS*
Specchio Cromo > 8 mm

* Solo per vetri fissi sp. 8 mm / Only for fixed glass, 8 mm thickness / Uniquement pour vitres fixes ép. 8 mm.

Serigrafie

Serigraphies . Sérigraphies

H 100 cm
> 6 mm
> 8 mm



X5
Fascia



X3
Stripes

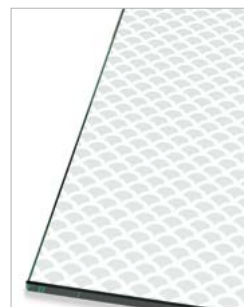

X2
Scaglie

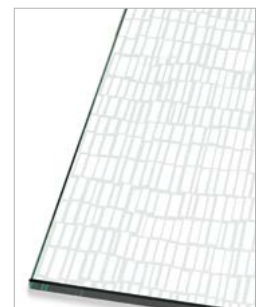

X4
Garza

Piatti doccia

Shower trays . Receveurs de douche

Mark

> Tekno Gelcoat



CM
Bianco

Feel 2.0

> Tekno Gelcoat

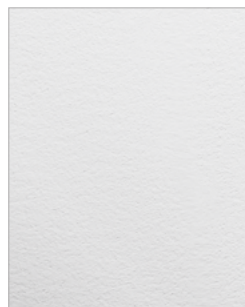

CM
Bianco

Linear

> Geacril

(effetto roccia)
(rock effect)
(effet rocher)

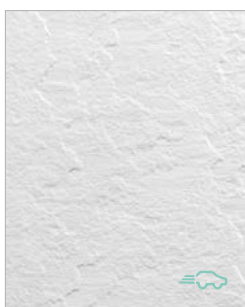

MA
Bianco



Colori Arbi opachi
Arbi matt colors
Couleurs Arbi mats

Synthesis

> Tekorstone

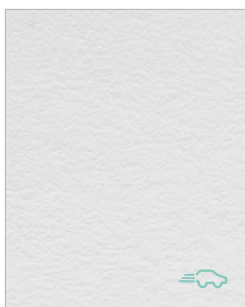

ES
Bianco



Colori Arbi opachi
Arbi matt colors
Couleurs Arbi mats

Silk

> Tekor
(solid surface)

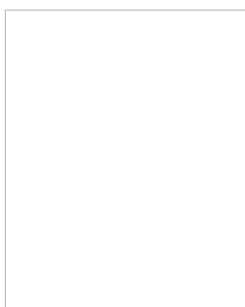

EQ
Bianco

Pegaso Aureo

> Laminam /
Gres



**A9 Laminam
Oxide Bianco**



**A4 Laminam
Oxide Nero**



**AF Laminam
Pietra di Savoia Perla**



**AE Laminam
Pietra di Savoia Grigia**



**AG Laminam
Pietra di Savoia Antracite**



**AA Laminam
Fokos Sale**



**AC Laminam
Fokos Terra**



**AB Laminam
Fokos Roccia**



**AD Laminam
Fokos Piombo**



**AI Laminam
Nero Greco**



**DW Laminam
Ossido Bruno**



**DV Laminam
Ossido Nero**



**DU Laminam
Ossido Verderame**



**AV Laminam
Pietra Grey**



**DJ Laminam
Calce Bianco**



**AJ Gres
Iris Ivory**



**AL Gres
Iris Silver**



**AM Gres
Iris Amber**



**AX Laminam
Statuarietto**



**DM Laminam
Pietra Piasentina**



**DO Laminam
Bianco Assoluto**



**DN Laminam
Calacatta Oro Venato**



**DO Laminam
Bianco Statuario Venato**

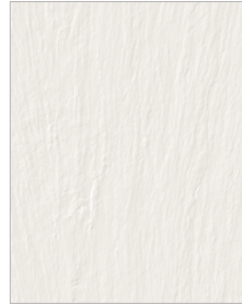

**DQ Laminam
Ardesia Spacco Bianco**



**DR Laminam
Ardesia Spacco Nero**



**DS Laminam
Pietra di Cardoso Nero**



**DS Laminam
Pietra di Cardoso Grigio**

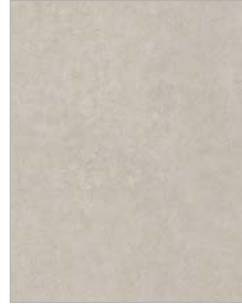

**D3 Laminam
Terra di Matera**



**D4 Laminam
Terra di Saturnia**



**DX Gres
Iseo Abujardado**



**DY Gres
Azalai Negro**



**D7 Gres
Iris Marsala**



**D8 Gres
Iris Azure**



**D9 Gres
Iris Steel Blue**

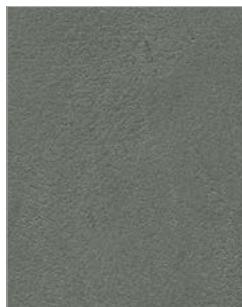

**D6 Gres
Iris Green**



**L1 Laminam
Alaska**



**L3 Laminam
Ankara**



**L2 Laminam
Amazonia**



**LO Laminam
Burgundy**



**L4 Laminam
Vulcano**

Ibra showers

CREDITS

design

Ibra Showers

images / photos

Quattroterzi Studio
Fotografica

color separation

Lucegroup.it

print

OGM

Febbraio 2026

The logo for IBRA SHOWERS features a black water drop icon to the left of the text. The word "IBRA" is in a bold, sans-serif font, and "SHOWERS" is in a regular weight of the same font, positioned directly below "IBRA".

Viale Lino Zanussi, 34/A
33070, Maron di Brugnera
Pordenone - Italy
T. +39 0434 624822

info@ibradocce.it
www.ibrashowers.it



