



IBRA
SHOWERS

VENTO

*BOX DOCCIA
SHOWER ENCLOSURES
PAROIS DE DOUCHE*

VENTO
> 8 mm

VENTO

Caratteristiche / features / caractéristiques

- | | | |
|---|--|---|
| <ul style="list-style-type: none"> > H 200 cm > Chiusura a calamita inserita su profilo in alluminio > Profilo a muro con pinza di fissaggio del vetro (no montante-compensatore) > Soft close in apertura e chiusura > Profilo traversa di dimensioni ridotte (33 mm) > Profili gocciolatoi in PVC trasparente antigoccia > Profilo inferiore di contenimento acqua in finitura > Vetri fissi senza profili inferiori > Profili di battuta con magnete integrato > Profilo maniglia a tutta altezza > Possibilità di fuori misura > Profili verticali dotati di tappi di chiusura trasparenti > Sistema di sgancio della porta scorrevole per una pulizia più agevole > Regolazione del sistema di scorrimento semplificato tramite grani > Montaggio rapido | <ul style="list-style-type: none"> > H 200 cm > Magnetic closing system inserted in the aluminium seal > Wall profile with glass fixing clamp (no compensator bar) > Opening and closing soft close system > Crossbar of small size (33mm) > Drip gaskets in transparent PVC anti-mould > Water containment channel matched with the profile > Fixed glass without lower profiles > Rebate profiles with integrated magnet > Full height handle-profile > Out of standard on request > Transparent upper covers on vertical profiles > Quick release system for an easiness cleaning > Sliding system simple to set > Easy to assemble | <ul style="list-style-type: none"> > H 200 cm > Fermeture magnetique inserée dans le profil en aluminium > Profilé mural avec pince de fermeture du verre (sans compensateur) > Soft close de série en ouvrant et en fermant la porte > Barre transversale avec dimensions réduites (33mm) > Profils en PVC contre l'éclaboussement > Profils inférieur pour le confinement de l'eau > Verres fixes sans profilés inférieurs > Profilés de porte avec aimant intégré > Profilé-poignée de la même hauteur du profilé > Sur mesure sur demande > Profils verticaux avec bouchons de fermeture transparents > Système de décrochage rapide pour nettoyer aisément > Réglage facile su système de coulissement > Assemblage rapide |
|---|--|---|

Vetri / glasses / verres

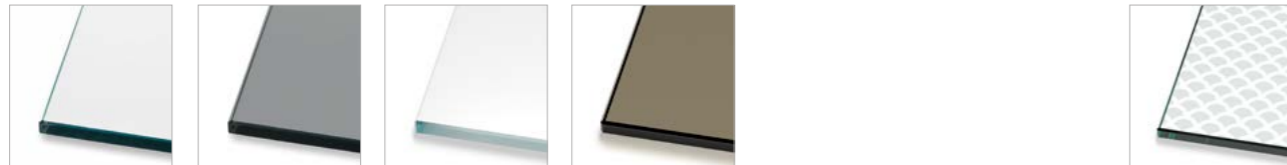

- | | | | | |
|-------------------|---------------------|----------------|--------------|--|
| 00
Trasparente | GE
Grigio Europa | SA
Satinato | BZ
Bronzo | X2-X3-X4-X5
Serigrafie
(v. pag. 95)
(see page 95)
Sérigraphies
(voir page 95) |
|-------------------|---------------------|----------------|--------------|--|

Profili / profiles / profils

STANDARD:

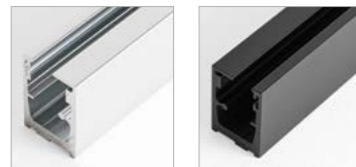

- | | |
|------------|-----------|
| B
Brill | N
Nero |
|------------|-----------|

SPECIAL:

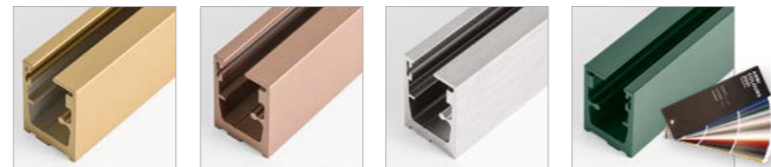

- | | | | |
|---------------------|----------------------|----------------------|------------------------------------|
| G
Oro spazzolato | C
Rame spazzolato | X
Inox spazzolato | 9
Laccato
Lacquered
Laqué |
|---------------------|----------------------|----------------------|------------------------------------|

VENTO - MANIGLIA



VENTO maniglia di serie as standard de série

- > Integrata nel profilo in alluminio
- > Integrated in the aluminium profile
- > Intégrée dans le profil en aluminium

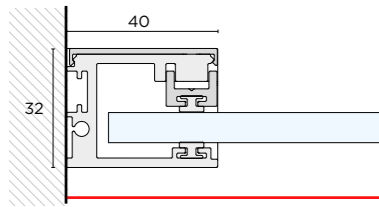

Fissaggio a muro

Wall mounting
Fixation au mur

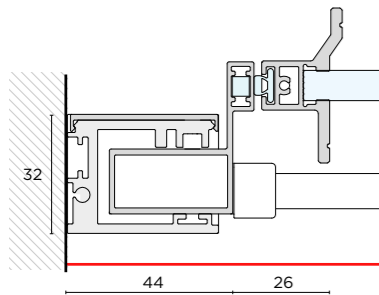

Battuta della porta scorrevole in nicchia

Abutment of the sliding door in a niche
Butée de la porte coulissante en niche

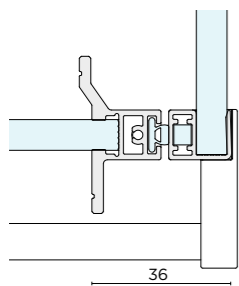

Battuta della porta scorrevole ad angolo con fisso laterale

Abutment of the sliding door in corner with fixed panel
Butée de la porte coulissante en coin avec coté fixe latéral

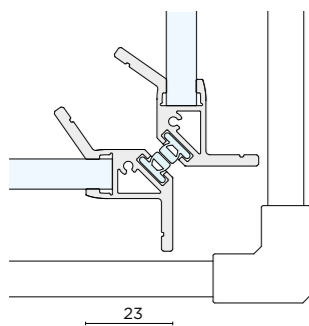

Angolo con 2 porte scorrevoli

Corner with 2 sliding doors
Angle avec 2 portes coulissantes

Configurazioni / configurations / configurations



A

ANGOLO > Walk-in

Walk-in
corner

Walk-in
en coin

p.24

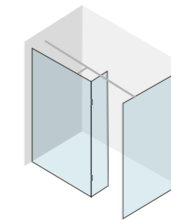

B

ANGOLO > Walk-in con fisso laterale

Walk-in corner
with fixed panel

Walk-in sur coin avec
paroi fixe laterale

p.26



C

PARETE > Angolo walk-in

Walk-in
wall

Walk-in
en coin
avec paroi

p.28

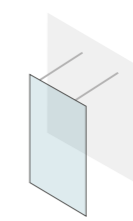

D

PARETE > Walk-in

Walk-in
wall

Walk-in
à paroi

p.30



NICCHIA > Scorrevole

1 sliding
door

Porte
coulissante

p.60

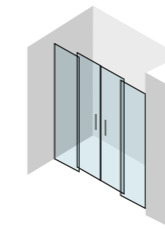

NICCHIA > Scorrevole 2 porte

2 sliding
doors

2 portes
coulissantes

p.62

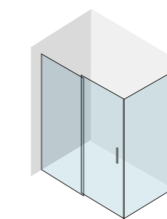

ANGOLO > Scorrevole 1 porta + fisso laterale

1 sliding door
+ fixed panel

Porte
coulissante
+ côté fixe

p.64



ANGOLO > Scorrevole 2 porte

2 sliding
doors

2 portes
coulissantes

p.66

VENTO: *WALK-IN*

VENTO *WALK-IN*

Di serie:
Standard:
De série:



A

ANGOLO
> Walk-in

Walk-in
corner

Walk-in
en coin

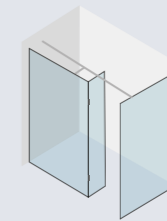

B

ANGOLO
> Walk-in con
fisso laterale

Walk-in corner
with fixed panel

Walk-in sur coin avec
paroi fixe laterale



C

PARETE
> Angolo
walk-in

Walk-in
wall

Walk-in
en coin
avec paroi



D

PARETE
> Walk-in

Walk-in
wall

Walk-in
à paroi

A richiesta
(contattare ufficio tecnico):
On request
(to be verified with technical
department):
Sur demande
(vérifier avec le département
technique):

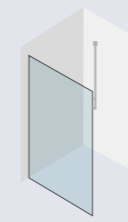

> Walk-in
a soffitto

Walk-in
fixed to the ceiling

Walk-in
à fixer au plafond

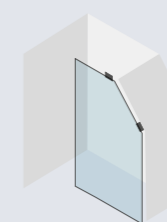

> Walk-in
sottotetto

Walk-in for
sloped ceiling

Walk-in pour
plafond incliné

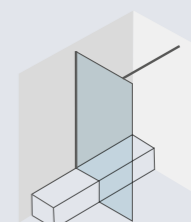

> Walk-in
sagomato

Walk-in
shaped panel

Walk-in
paroi façonnée

Dettagli / details / détails



Braccetto dritto a parete:
Un elemento estetico e funzionale che
sostiene il vetro.

Straight wall-mounted support arm:
A functional and aesthetic feature that
supports the glass.

Bras droit à paroi:
Un élément esthétique et fonctionnel à
soutien du verre.



Braccetto a T:
Una barra di sostegno per vetri di grandi
dimensioni.

T-shaped support arm:
A support bar for large glass panels.

Bras en forme de T:
Une barre de soutien pour verre de
grandes dimensions.



Aletta girevole:
Accessorio che può essere aggiunto dopo
l'installazione.

Deflector:
This accessory can be added after
installation.

Ailette:
Accessoire qui peut être ajouté après
installation.

LEGENDA KEY / LÉGENDE

F fisso / fixed panel / côté fixe
L lato / lateral fixed panel / côté fixe latéral
A apertura / opening / entrée
P porta / door / porte

01.

**Walk-in ad angolo
con fisso laterale + aletta**
Terra + vetro trasparente

*Walk-in corner
with fixed panel + deflector*
Terra + trasparente glass

*Walk-in en coin
avec paroi fixe laterale + ailette*
Terra + verre transparente

Piatto doccia:
Silk Bianco L 160 x P 80 cm

Shower tray:
Silk Bianco W 160 x D 80 cm

Receveur:
Silk Bianco L 160 x P 80 cm





Braccetto colore Terra
dal design minimale

Support-arm in Terra finish
with a minimal design

Bras en finition Terra
avec un design minimaliste

**Vetro in appoggio
sul piatto**
per facilitare la
pulizia

**Glass panel directly
mounted into the tray**
for an easier cleaning

**Paroi apposée sur
le receveur**
pour un nettoyage
plus simple



02.

**Walk-in
ad angolo**
brill + vetro trasparente

**Walk-in
corner**
in brill + trasparente glass

**Walk-in
en coin**
en brill + verre transparente



Piatto doccia:
Pegaso Laminam Statuarietto
L 140 x P 80 cm

Shower tray:
Pegaso Laminam Statuarietto
W 140 x D 80 cm

Receveur:
Pegaso Laminam Statuarietto
L 140 x P 80 cm



Inserto in Laminam
abbinato al piatto doccia

Laminam insert
matching with the shower tray

Insert en Laminam
assorti au receveur de douche

**Accessorio fissato
sul vetro**
portasalviette da un lato
e mensola porta oggetti
dall'altro

**Accessory fixed
on the glass**
used as towel-holder
on one side,
and used as shelf
on the other side

Accessoire fixé au verre
porte-serviette d'un côté,
et à l'étagère porte-objet
de l'autre côté



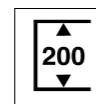

Altezza 200 cm
Height 200 cm
Hauteur 200 cm

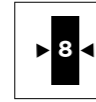

Vetro sp. 8 mm
Glass th. 8 mm
Verre ép. 8 mm



Fuori misura:
altezza max 220 cm / larghezza max 160 cm
Out of standard:
height max. 220 cm / width max. 160 cm
Sur demande:
hauteur max. 220 cm / largeur max. 160 cm



Reversibile
Reversible
Réversible



Braccetto accorciabile in opera compreso nel prezzo
Stabilizing bar to be cutted during installation included
Barre de soutien à couper en cours de réalisation comprise dans le prix.

Configurazioni:
Configurations:
Configurations:

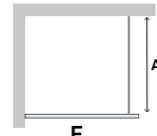

VERSIONE SX
Left
Gauche

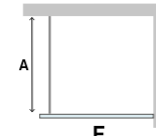

VERSIONE DX
Right
Droite

MAGGIORAZIONI / SURCHARGES / SUPPLÉMENTS

Fuori Misura:
Out of standard:
Sur mesure:



(richiedere fattibilità)
(ask for feasibility)
(vérifier la faisabilité avec le service technique)

Vetro con serigrafie:
Serigraphies (see page 95):
Sérigraphies (voir page 95):



maggiorazione dal TRASPARENTE
increase on the TRASPARENTE price
à appliquer sur le prix du TRASPARENTE

Trattamento anticalcare:
Glass treatment:
Traitement verre:



Lato
Side
Verre

Accessorio Chronos:
Chronos accessory:
Chronos accessoire:



vedi pag. 32
see page 32
voir page 32



F - FISSO / FIXED PANEL / CÔTÉ FIXE

ART. ITEM ART.	ESTENSIBILITÀ EXTENSIBILITY EXTENSIBILITÉ	PIATTO TRAY RECEVEUR	PROFILO / PROFILE / PROFIL					
			BRILL / NERO		INOX / ORO / RAME		COLORATO	
			VETRI / GLASS / VERRE					
			○	●	○	●	○	●
D8WA500	77,5 - 79,5	80						
D8WA505	82,5 - 84,5	85						
D8WA510	87,5 - 89,5	90						
D8WA515	92,5 - 94,5	95						
D8WA520	97,5 - 99,5	100						
D8WA525	102,5 - 104,5	105						
D8WA530	107,5 - 109,5	110						
D8WA535	112,5 - 114,5	115						
D8WA540	117,5 - 119,5	120						
D8WA545	122,5 - 124,5	125						
D8WA550	127,5 - 129,5	130						
D8WA555	132,5 - 134,5	135						
D8WA560	137,5 - 139,5	140						
D8WA565	142,5 - 144,5	145						
D8WA570	147,5 - 149,5	150						
D8WA575	152,5 - 154,5	155						
D8WA580	157,5 - 159,5	160						

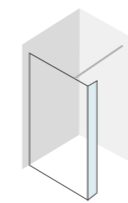

OPTIONAL - GIREVOLE / DEFLECTOR / AILETTE

ART. ITEM ART.	LUNGHEZZA WIDTH LONGUEUR	CERNIERE / HINGES / CHARNIÈRES					
		BRILL / NERO		INOX / ORO / RAME		COLORATO	
		VETRI / GLASS / VERRE					
		○	●	○	●	○	●
D8AG100	30						
D8AG200	40						

VETRI / GLASS / VERRE

- TRASPARENTE
- GRIGIO EUROPA | SATINATO | BRONZO

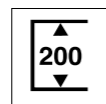

Altezza 200 cm
Height 200 cm
Hauteur 200 cm

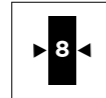

Vetro sp. 8 mm
Glass th. 8 mm
Verre ép. 8 mm



Fuori misura:
altezza max 220 cm / larghezza max 160 cm
Out of standard:
height max. 220 cm / width max. 160 cm
Sur demande:
hauteur max. 220 cm / largeur max. 160 cm

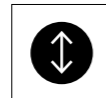

Reversibile
Reversible
Réversible



Braccetto accorciabile in opera compreso nel prezzo
Stabilizing bar to be cutted during installation included
Barre de soutien à couper en cours de réalisation comprise dans le prix.

Configurazioni:
Configurations:
Configurations:

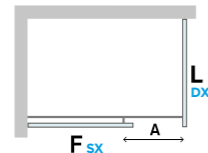

VERSIONE SX
Left
Gauche

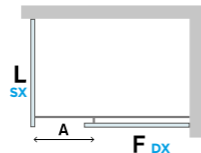

VERSIONE DX
Right
Droite

MAGGIORAZIONI / SURCHARGES / SUPPLÉMENTS

Fuori Misura:
Out of standard:
Sur mesure:



(richiedere fattibilità)
(ask for feasibility)
(vérifier la faisabilité avec le service technique)

Vetro con serigrafie:
Serigraphies (see page 95):
Sérigraphies (voir page 95):



maggiorazione dal TRASPARENTE
increase on the TRASPARENTE price
à appliquer sur le prix du TRASPARENTE

Trattamento anticalcare:
Glass treatment:
Traitement verre:



Lato
Side
Verre

Accessorio Chronos:
Chronos accessory:
Chronos accessoire:

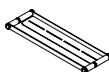

vedi pag. 32
see page 32
voir page 32



F - FISSO / FIXED PANEL / CÔTÉ FIXE

ART. ITEM ART.	ESTENSIBILITÀ EXTENSIBILITY EXTENSIBILITÉ	PROFILO / PROFILE / PROFIL					
		BRILL / NERO		INOX /ORO/RAME		COLORATO	
		VETRI / GLASS / VERRE					
		<input type="radio"/>	<input checked="" type="radio"/>	<input type="radio"/>	<input checked="" type="radio"/>	<input type="radio"/>	<input checked="" type="radio"/>
D8WA600	67,5 - 69,5						
D8WA605	72,5 - 74,5						
D8WA610	77,5 - 79,5						
D8WA615	82,5 - 84,5						
D8WA620	87,5 - 89,5						
D8WA625	92,5 - 94,5						
D8WA630	97,5 - 99,5						
D8WA635	102,5 - 104,5						
D8WA640	107,5 - 109,5						
D8WA645	112,5 - 114,5						
D8WA650	117,5 - 119,5						

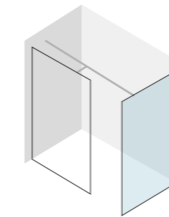

L - FISSO / FIXED PANEL / CÔTÉ FIXE

ART. ITEM ART.	ESTENSIBILITÀ EXTENSIBILITY EXTENSIBILITÉ	PIATTO SHOWER TRAY RECEVEUR	PROFILO / PROFILE / PROFIL					
			BRILL / NERO		INOX /ORO/RAME		COLORATO	
			VETRI / GLASS / VERRE					
			<input type="radio"/>	<input checked="" type="radio"/>	<input type="radio"/>	<input checked="" type="radio"/>	<input type="radio"/>	<input checked="" type="radio"/>
D8WA655	67,5 - 69,5	70						
D8WA660	72,5 - 74,5	75						
D8WA665	77,5 - 79,5	80						
D8WA670	82,5 - 84,5	85						
D8WA675	87,5 - 89,5	90						
D8WA680	92,5 - 94,5	95						
D8WA685	97,5 - 99,5	100						

OPTIONAL - GIREVOLE / DEFLECTOR / AILETTE

ART. ITEM ART.	LUNGHEZZA WIDTH LONGUEUR	CERNIERE / HINGES / CHARNIÈRES					
		BRILL / NERO		INOX /ORO/RAME		COLORATO	
		VETRI / GLASS / VERRE					
		<input type="radio"/>	<input checked="" type="radio"/>	<input type="radio"/>	<input checked="" type="radio"/>	<input type="radio"/>	<input checked="" type="radio"/>
D8AG100	30						
D8AG200	40						

VETRI / GLASS / VERRE

- TRASPARENTE
- GRIGIO EUROPA | SATINATO | BRONZO

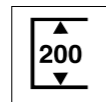

Altezza 200 cm
Height 200 cm
Hauteur 200 cm

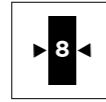

Vetro sp. 8 mm
Glass th. 8 mm
Verre ép. 8 mm



Fuori misura:
altezza max 220 cm / larghezza max 160 cm
Out of standard:
height max. 220 cm / width max. 160 cm
Sur demande:
hauteur max. 220 cm / largeur max. 160 cm

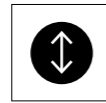

Reversibile
Reversible
Réversible



Braccetto accorciabile in opera compreso nel prezzo
Stabilizing bar to be cutted during installation included
Barre de soutien à couper en cours de réalisation comprise dans le prix

Configurazioni:
Configurations:
Configurations:



VERSIONE SX
Left
Gauche



VERSIONE DX
Right
Droite

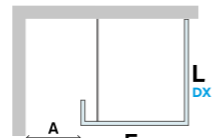

VERSIONE DX
Left
Gauche

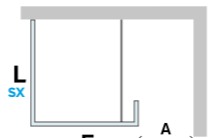

VERSIONE SX
Right
Droite

MAGGIORAZIONI / SURCHARGES / SUPPLÉMENTS

Fuori Misura:
Out of standard:
Sur mesure:



(richiedere fattibilità)
(ask for feasibility)
(vérifier la faisabilité avec le service technique)

Vetro con serigrafie:
Serigraphies (see page 95):
Sérigraphies (voir page 95):



maggiorazione dal TRASPARENTE
increase on the TRASPARENTE price
à appliquer sur le prix du TRASPARENTE

Trattamento anticalcare:
Glass treatment:
Traitement verre:



Lato
Side
Verre

Accessorio Chronos:
Chronos accessory:
Chronos accessoire:

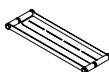

vedi pag. 32
see page 32
voir page 32



F - FISSO / FIXED PANEL / CÔTÉ FIXE

ART. ITEM ART.	L. W. L.	PIATTO SHOWER TRAY RECEVEUR	PROFILO / PROFILE / PROFIL					
			BRILL / NERO		INOX / ORO / RAME		COLORATO	
			VETRI / GLASS / VERRE					
			○	●	○	●	○	●
D8WP100	69	-						
D8WP105	74	-						
D8WP110	79	-						
D8WP115	84	-						
D8WP120	89	-						
D8WP125	94	-						
D8WP130	99	-						
D8WP135	104	-						
D8WP140	109	-						
D8WP145	114	-						
D8WP150	119	-						

ATTENZIONE
Specificare il verso al momento dell'ordine.

ATTENTION
Indicate the side in the order.

ATTENTION
Indiquer le vers dans la commande.

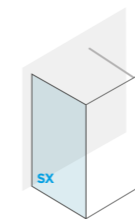

L - FISSO / FIXED PANEL / CÔTÉ FIXE

ART. ITEM ART.	ESTENSIBILITÀ EXTENSIBILITY EXTENSIBILITÉ	PIATTO SHOWER TRAY RECEVEUR	PROFILO / PROFILE / PROFIL					
			BRILL / NERO		INOX / ORO / RAME		COLORATO	
			VETRI / GLASS / VERRE					
			○	●	○	●	○	●
D8WA655	67,5 - 69,5	70						
D8WA660	72,5 - 74,5	75						
D8WA665	77,5 - 79,5	80						
D8WA670	82,5 - 84,5	85						
D8WA675	87,5 - 89,5	90						
D8WA680	92,5 - 94,5	95						
D8WA685	97,5 - 99,5	100						

ATTENZIONE
Specificare il verso al momento dell'ordine.

ATTENTION
Indicate the side in the order.

ATTENTION
Indiquer le vers dans la commande.

OPTIONAL - GIREVOLE / DEFLECTOR / AILETTE

ART. ITEM ART.	LUNGHEZZA WIDTH LONGUEUR	CERNIERE / HINGES / CHARNIÈRES						
		BRILL / NERO		INOX / ORO / RAME		COLORATO		
			VETRI / GLASS / VERRE					
			○	●	○	●	○	●
D8AG100	30							
D8AG200	40							

VETRI / GLASS / VERRE

○ TRASPARENTE

● GRIGIO EUROPA | SATINATO | BRONZO

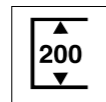

Altezza 200 cm
Height 200 cm
Hauteur 200 cm

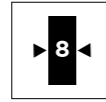

Vetro sp. 8 mm
Glass th. 8 mm
Verre ép. 8 mm



Fuori misura:
altezza max 220 cm / larghezza max 160 cm
Out of standard:
height max. 220 cm / width max. 160 cm
Sur demande:
hauteur max. 220 cm / largeur max. 160 cm

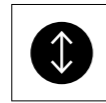

Reversibile
Reversible
Réversible



Braccetti accorciabili in opera compresi nel prezzo
Stabilizing bars to be cutted during installation included
Barres de soutien à couper en cours de réalisation comprises dans le prix.

Configurazioni:
Configurations:
Configurations:

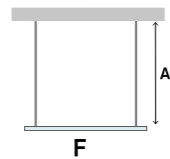

VERSIONE SX / DX
Left / Right
Gauche / Droite

MAGGIORAZIONI / SURCHARGES / SUPPLÉMENTS

Fuori Misura:
Out of standard:
Sur mesure:



(richiedere fattibilità)
(ask for feasibility)
(vérifier la faisabilité avec le service technique)

Vetro con serigrafie:
Serigraphies (see page 95):
Sérigraphies (voir page 95):



maggiorazione dal TRASPARENTE
increase on the TRASPARENTE price
à appliquer sur le prix du TRASPARENTE

Trattamento anticalcare:
Glass treatment:
Traitement verre:



Lato
Side
Verre

Accessorio Chronos:
Chronos accessory:
Chronos accessoire:



vedi pag. 32
see page 32
voir page 32

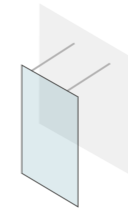

F - FISSO / FIXED PANEL / CÔTÉ FIXE

ART. ITEM ART.	L. W. L.	PIATTO SHOWER TRAY RECEVEUR	PROFILO / PROFILE / PROFIL					
			BRILL / NERO		INOX / ORO / RAME		COLORATO	
			VETRI / GLASS / VERRE					
			○	●	○	●	○	●
D8WP195	67	-						
D8WP200	72	-						
D8WP205	77	-						
D8WP210	82	-						
D8WP215	87	-						
D8WP220	92	-						
D8WP225	97	-						
D8WP230	102	-						
D8WP235	107	-						
D8WP240	112	-						
D8WP245	117	-						
D8WP250	122	-						
D8WP255	127	-						
D8WP260	132	-						
D8WP265	137	-						

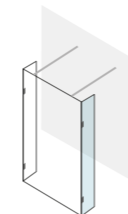

OPTIONAL - GIREVOLE / DEFLECTOR / AILETTE

ART. ITEM ART.	LUNGHEZZA WIDTH LONGUEUR	CERNIERE / HINGES / CHARNIÈRES					
		BRILL / NERO		INOX / ORO / RAME		COLORATO	
		VETRI / GLASS / VERRE					
		○	●	○	●	○	●
D8AG100	30						
D8AG200	40						

VETRI / GLASS / VERRE

- TRASPARENTE
- GRIGIO EUROPA | SATINATO | BRONZO

ACCESSORIO CHRONOS

Accessorio Chronos
Chronos accessory
Accessoire Chronos

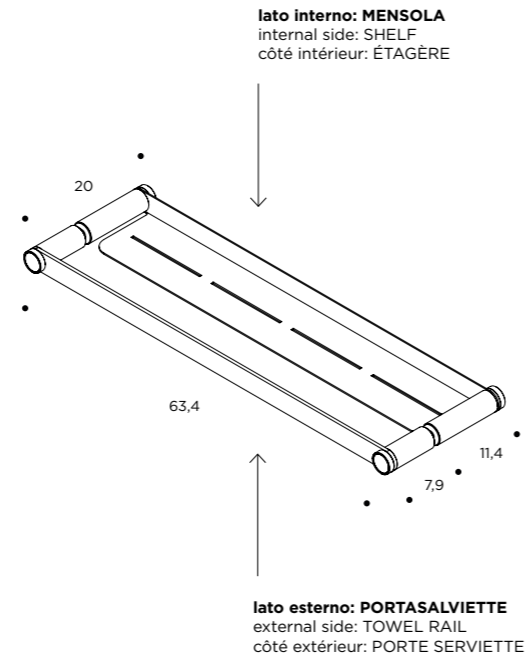

**Accessorio fissato sul vetro:
portasalviette da un lato e mensola porta oggetti dall'altro**

Metal shelf H 52.7 cm
It can be positioned on glass th. 6 - 8 mm

Étagère en métal H 52,7 cm
Elle est positionnable sur verre ép. 6 - 8 mm

Finiture / finishes / finitions

STANDARD:



B
Brill



N
Nero

SU RICHIESTA / ON DEMAND / ON REQUEST:



G
Oro spazzolato



C
Rame spazzolato



X
Inox spazzolato



9
Laccato
Lacquered
Laqué

DESCRIZIONE DESCRIPTION DESCRIPTION	ART. ITEM ART.	PREZZO BRILL / NERO PRICE BRILL / NERO PRIX BRILL / NERO
MENSOLA / PORTASALVIETTE SHELF / TOWEL RAIL ÉTAGÈRE / PORTE SERVIETTE	A0004	

VENTO: **SCORREVOLE** **SLIDING DOOR** **COULISSANTE**

LEGENDA KEY / LÉGENDE

F fisso / fixed panel / côté fixe
L lato / fixed panel lateral / côté fixe latéral
A apertura / opening / entrée
P porta / door / porte

VENTO **SCORREVOLE**

Di serie:
Standard:
De série:



NICCHIA
> Scorrevole

1 sliding door

Porte coulissante

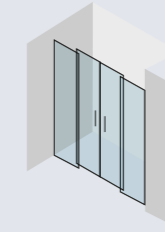

NICCHIA
> Scorrevole
2 porte

2 sliding doors

2 portes coulissantes



ANGOLO
> Scorrevole 1 porta
+ fisso laterale

1 sliding door
+ fixed panel

Porte coulissante
+ côté fixe

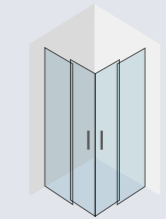

ANGOLO
> Scorrevole
2 porte

2 sliding doors

2 portes coulissantes

A richiesta
(contattare ufficio tecnico):
On request
(to be verified with technical department):
Sur demande
(vérifier avec le département technique):



ANGOLO
> Scorrevole + fisso
laterale sottotetto

Sliding door with in-line fixed panel + side panel for sloped ceiling

Porte coulissante avec paroi fixe alignée + paroi fixe latérale pour plafond incliné

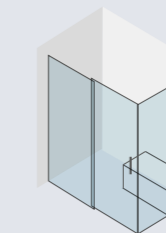

ANGOLO
> Scorrevole sagomato
+ fisso laterale

Sliding door with in-line fixed panel + shaped fixed lateral panel

Porte coulissante avec paroi fixe alignée + paroi fixe latérale façonnée

Dettagli / details / détails



Angolo a 45°:
Nella versione a due ante scorrevoli i profili sono tagliati a 45° per una giunzione minimale.

45° corner:
In the configuration with 2 sliding doors profiles are 45° cut for a minimalist junction.

Coin en 45°:
dans la configuration avec deux portes coulissantes, les profilés sont coupés à 45° pour obtenir une jonction minimaliste.



Sgancio della porta:
Un sistema utile per facilitare le operazioni di pulizia.

Quick release system:
A useful system for the cleaning operations.

Décrochage de la porte:
Un système utile pour le nettoyage.



Pinza in alluminio:
permette di eliminare il profilo della traversa superiore.

Aluminium clamp:
it allow to eliminate the profile of the upper transversal bar.

Pince en aluminium:
elle permet de supprimer le profilé de la barre transversale supérieure.

03.

**Porta scorrevole ad angolo
+ fisso laterale**
Rame + vetro Bronzo

*Sliding door + fixed lateral panel
+ fixed panel*
in Rame + Bronzo glass

*Porte coulissante
+ côté fixe lateral*
en Rame + verre Bronzo

Piatto doccia:
Synthesis Bianco
L 160 x P 80 cm

Shower tray:
Synthesis Bianco
W 160 x D 80 cm

Receveur:
Synthesis Bianco
L 160 x P 80 cm





**Sgancio rapido
della porta**
per agevolare
la pulizia

**Quick release
system**
to easily clean

**Décrochage rapide
de la porte**
pour simplifier le nettoyage



04.

**Doppia porta scorrevole
ad angolo**
Inox + vetro trasparente

**2 sliding doors
corner**
in Inox + trasparente glass

**2 Portes coulissante
en coin**
en Inox + verre transparente



Piatto doccia:
Arya Bianco
L 80 x P 80 cm

Shower tray:
Arya Bianco
W 80 x D 80 cm

Receveur:
Arya Bianco
L 80 x P 80 cm



Traversa con taglio a 45°:
per una giunzione
minimale

**Transversal bar
with 45° cut:**
to have a minimal
junction

**Barre transversale avec
découpe à 45°**
pour une jonction
minimaliste



05.

**Porta scorrevole ad angolo
+ fisso laterale**
Bluriva + vetro trasparente

*Sliding door + fixed lateral panel
+ fixed panel*
in Bluriva + trasparente glass

*Porte coulissante
+ côté fixe lateral*
en Bluriva + verre transparente

Piatto doccia:
Synthesis Tan Pink
L 120 x P 80 cm

Shower tray:
Synthesis Tan Pink
W 120 x D 80 cm

Receveur:
Synthesis Tan Pink
L 120 x P 80 cm





Soft close
e attuatori
a scomparsa

Soft close system
and retractable
actuators

Fermeture amortie
et actionneurs
escamotables



**Guarnizione
magnetica nera**

**Black magnetic
gasket**

**Joint magnetique
noir**





06.

**Scorrevole
in nicchia**
Oro + vetro trasparente

*Sliding door
in niche*
in Oro + trasparente glass

**Porte coulissante
en coin**
en Oro + verre transparente

Piatto doccia:
Pegaso Gres Seminato Candido
L 140 x P 80 cm

Shower tray:
Pegaso Gres Seminato Candido
W 140 x D 80 cm

Receveur:
Pegaso Gres Seminato Candido
L 140 x P 80 cm



**Piatto Pegaso
con cover in Gres**
nella stessa finitura
del piatto doccia

**Pegaso shower tray
with cover in Gres**
matched with the
shower tray

**Receveur de douche
Pegaso avec cache
bonde en Gres**
assorti au receveur

**Maniglia Vento
minimale**
su tutta la lunghezza
del profilo del box

**Minimal Vento
handle**
full height

**Poignée Vento
minimaliste,**
de la même hauteur
du profilé



07.

**Doppia porta scorrevole
ad angolo**
Skin + vetro trasparente

*2 sliding doors
in corner*
Skin + trasparente glass

*2 porte coulissantes
en coin*
Skin + verre transparente

Piatto doccia:
Synthesis Skin L 120 x P 80 cm

Shower tray:
Synthesis Skin W 120 x D 80 cm

Receveur:
Synthesis Skin L 120 x P 80 cm





**Maniglia Vento
minimale**
su tutta la lunghezza
del profilo del box

**Minimal Vento
handle**
full height

**Poignée Vento
minimaliste,**
de la même hauteur
du profilé





08.

**Doppia porta scorrevole
in nicchia**
Burro + vetro trasparente

*2 sliding doors
in niche*
Burro + trasparente glass

*2 porte coulissantes
en niche*
Burro + verre transparente

Piatto doccia:
Silk Bianco L 180 x P 80 cm

Shower tray:
Silk Bianco W 180 x D 80 cm

Receveur:
Silk Bianco L 180 x P 80 cm

Profilo portamagnete
con maniglia integrata
a tutta altezza

Profil with
integrated magnet
and full height
integrated handle

Profilé avec
aimant intégré
et poignée de la
même hauteur



VENTO SCORREVOLE

Nicchia
Niche
Niche

Porta scorrevole
Sliding door
Porte coulissante

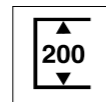

Altezza 200 cm
Height 200 cm
Hauteur 200 cm

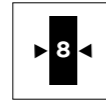

Vetro sp. 8 mm
Glass th. 8 mm
Verre ép. 8 mm



Fuori misura:
altezza max 220 cm / larghezza max 160 cm
Out of standard:
height max. 220 cm / width max. 160 cm
Sur demande:
hauteur max. 220 cm / largeur max. 160 cm

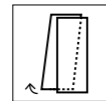

Sgancio rapido della porta
Door with quick release system
Décrochage rapide de la porte



Regolazione inclinazione porta
Inclination door adjustment
Réglage inclinaison de la porte



Sistema Soft-Close silenzioso di serie
Silent Soft-Close system as standard
Système silencieux Soft-Close de série

Configurazioni:
Configurations:
Configurations:

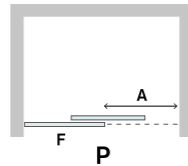

VERSIONE SX
Left
Gauche

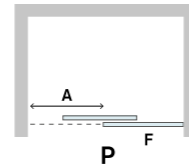

VERSIONE DX
Right
Droite

Trattamento anticalcare:
Glass treatment:
Traitement verre:



Incluso nel prezzo
Included in the price
compris dans le prix

MAGGIORAZIONI / SURCHARGES / SUPPLÉMENTS

Fuori Misura:
Out of standard:
Sur mesure:



(richiedere fattibilità)
(ask for feasibility)
(vérifier la faisabilité avec le service technique)

Vetro con serigrafie:
Serigraphies (see page 95):
Sérigraphies (voir page 95):



maggiorazione dal TRASPARENTE
increase on the TRASPARENTE price
à appliquer sur le prix du TRASPARENTE

VENTO SCORREVOLE

Nicchia
Niche
Niche

Porta scorrevole
Sliding door
Porte coulissante

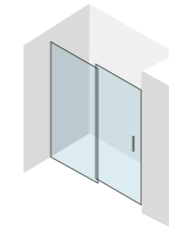

ATTENZIONE
Specificare il verso al momento dell'ordine.

ATTENTION
Indicate the side in the order.

ATTENTION
Indiquer le vers dans la commande.

P - PORTA SCORREVOLE / SLIDING DOOR / PORTE COULISSANTE

ART. ITEM ART.	ESTENSIBILITÀ EXTENSIBILITY EXTENSIBILITÉ	PIATTO TRAY RECEVEUR	APERTURA OPENING ENTRÉE	FISSO FIXED FIXE	PROFILO / PROFILE / PROFIL					
					BRILL / NERO		INOX / ORO / RAME		COLORATO	
					VETRI / GLASS / VERRE					
					○	●	○	●	○	●
D8SN500	96 - 99	100	40	47						
D8SN505	101 - 104	105	43	49						
D8SN510	106 - 109	110	43	54						
D8SN515	111 - 114	115	45	51						
D8SN520	116 - 119	120	50	56						
D8SN525	121 - 124	125	53	59						
D8SN530	126 - 129	130	53	64						
D8SN535	131 - 134	135	58	64						
D8SN540	136 - 139	140	58	69						
D8SN545	141 - 144	145	58	74						
D8SN550	146 - 149	150	63	69						
D8SN555	151 - 154	155	68	74						
D8SN560	156 - 159	160	68	79						

VETRI / GLASS / VERRE

○ TRASPARENTE

● GRIGIO EUROPA | SATINATO | BRONZO

VENTO SCORREVOLE

Nicchia
Niche
Niche

2 porte scorrevoli
2 sliding doors
2 portes coulissantes

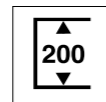

Altezza 200 cm
Height 200 cm
Hauteur 200 cm

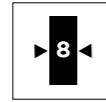

Vetro sp. 8 mm
Glass th. 8 mm
Verre ép. 8 mm



Fuori misura:
altezza max 220 cm / larghezza max 200 cm
Out of standard:
height max. 220 cm / width max. 200 cm
Sur demande:
hauteur max. 220 cm / largeur max. 200 cm

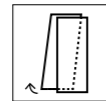

Sgancio rapido della porta
Door with quick release system
Décrochage rapide de la porte



Regolazione inclinazione porta
Inclination door adjustment
Réglage inclinaison de la porte



Sistema Soft-Close silenzioso di serie
Silent Soft-Close system as standard
Système silencieux Soft-Close de série

Configurazioni:
Configurations:
Configurations:

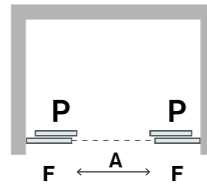

VERSIONE SX / DX
Left / Right
Gauche / Droite

Trattamento anticalcare:
Glass treatment:
Traitement verre:



Incluso nel prezzo
Included in the price
compris dans le prix

MAGGIORAZIONI / SURCHARGES / SUPPLÉMENTS

Fuori Misura:
Out of standard:
Sur mesure:



(richiedere fattibilità)
(ask for feasibility)
(vérifier la faisabilité avec le service technique)

Vetro con serigrafie:
Serigraphies (see page 95):
Sérigraphies (voir page 95):



maggiorazione dal TRASPARENTE
increase on the TRASPARENTE price
à appliquer sur le prix du TRASPARENTE

VENTO SCORREVOLE

Nicchia
Niche
Niche

2 porte scorrevoli
2 sliding doors
2 portes coulissantes

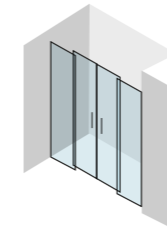

P - PORTE SCORREVOLI / SLIDING DOORS / PORTES COULISSANTES

ART. ITEM ART.	ESTENSIBILITÀ EXTENSIBILITY EXTENSIBILITÉ	PIATTO TRAY RECEVEUR	APERTURA OPENING ENTRÉE	FISSO FIXED FIXE	PROFILO / PROFILE / PROFIL					
					BRILL / NERO		INOX / ORO / RAME		COLORATO	
					VETRI / GLASS / VERRE					
					○	●	○	●	○	●
D8SN600	136 - 139	140	54	34						
D8SN605	141 - 144	145	60	36						
D8SN610	146 - 149	150	60	39						
D8SN615	151 - 154	155	60	36						
D8SN620	156 - 159	160	64	39						
D8SN625	161 - 164	165	68	41						
D8SN630	166 - 169	170	68	44						
D8SN635	171 - 174	175	68	46						
D8SN640	176 - 179	180	73	44						

VETRI / GLASS / VERRE

○ TRASPARENTE

● GRIGIO EUROPA | SATINATO | BRONZO

VENTO SCORREVOLE

Angolo
Corner
Coin

Porta scorrevole + fisso laterale
Sliding door + fixed lateral panel
Porte coulissante + côté fixe latéral

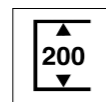

Altezza 200 cm
Height 200 cm
Hauteur 200 cm

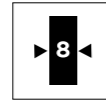

Vetro sp. 8 mm
Glass th. 8 mm
Verre ép. 8 mm



Fuori misura:
altezza max 220 cm / larghezza max 160 cm /
profondità max 100 cm
Out of standard:
height max. 220 cm / width max. 160 cm /
depth max. 100 cm
Sur demande:
hauteur max. 220 cm / largeur max. 160 cm /
profondeur max. 100 cm

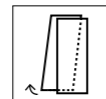

Sgancio rapido della porta
Door with quick release system
Décrochage rapide de la porte



Regolazione inclinazione porta
Inclination door adjustment
Réglage inclinaison de la porte



Sistema Soft-Close silenzioso di serie
Silent Soft-Close system as standard
Système silencieux Soft-Close de série

Configurazioni

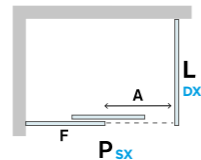

VERSIONE SX
Left
Gauche

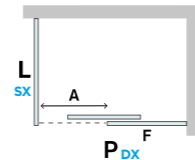

VERSIONE DX
Right
Droite

Trattamento anticalcare:
Glass treatment:
Traitement verre:



Incluso nel prezzo
Included in the price
compris dans le prix

MAGGIORAZIONI / SURCHARGES / SUPPLÉMENTS

Fuori Misura:
Out of standard:
Sur mesure:



(richiedere fattibilità)
(ask for feasibility)
(vérifier la faisabilité avec le service technique)

Vetro con serigrafie:
Serigraphies (see page 95):
Sérigraphies (voir page 95):



maggiorazione dal TRASPARENTE
increase on the TRASPARENTE price
à appliquer sur le prix du TRASPARENTE

VENTO SCORREVOLE

Angolo
Corner
Coin

Porta scorrevole + fisso laterale
Sliding door + fixed panel
Porte coulissante + côté fixe

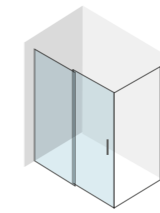

ATTENZIONE
Specificare il verso al momento dell'ordine.

ATTENTION
Indicate the side in the order.

ATTENTION
Indiquer le vers dans la commande.

P - PORTA SCORREVOLE / SLIDING DOOR / PORTE COULISSANTE

ART. ITEM ART.	ESTENSIBILITÀ EXTENSIBILITY EXTENSIBILITÉ	PIATTO TRAY RECEVEUR	APERTURA OPENING ENTRÉE	FISSO FIXED FIXE	PROFILO / PROFILE / PROFIL					
					BRILL / NERO		INOX / ORO / RAME		COLORATO	
					VETRI / GLASS / VERRE					
					○	●	○	●	○	●
D8SA700	97,5 - 99,5	100	42	48						
D8SA705	102,5 - 104,5	105	43	53						
D8SA710	107,5 - 109,5	110	44	51						
D8SA715	112,5 - 114,5	115	50	56						
D8SA720	117,5 - 119,5	120	52	58						
D8SA725	122,5 - 124,5	125	53	63						
D8SA730	127,5 - 129,5	130	57	63						
D8SA735	132,5 - 134,5	135	58	68						
D8SA740	137,5 - 139,5	140	58	73						
D8SA745	142,5 - 144,5	145	58	78						
D8SA750	147,5 - 149,5	150	67	73						
D8SA755	152,5 - 154,5	155	68	78						
D8SA760	157,5 - 159,5	160	68	83						

L - FISSO / FIXED LATÉRAL PANEL / CÔTÉ FIXE LATÉRAL

ART. ITEM ART.	ESTENSIBILITÀ EXTENSIBILITY EXTENSIBILITÉ	PIATTO TRAY RECEVEUR			PROFILO / PROFILE / PROFIL					
					BRILL / NERO		INOX / ORO / RAME		COLORATO	
					VETRI / GLASS / VERRE					
					○	●	○	●	○	●
D8SA765	67,5 - 69,5	70								
D8SA770	72,5 - 74,5	75								
D8SA775	77,5 - 79,5	80								
D8SA780	82,5 - 84,5	85								
D8SA785	87,5 - 89,5	90								
D8SA790	92,5 - 94,5	95								
D8SA795	97,5 - 99,5	100								

VETRI / GLASS / VERRE

○ TRASPARENTE

● BRONZO | SATINATO | GRIGIO EUROPA

VENTO SCORREVOLE

Angolo
Corner
Coin

2 porte scorrevoli
2 sliding door
2 portes coulissantes

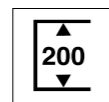

Altezza 200 cm
Height 200 cm
Hauteur 200 cm

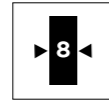

Vetro sp. 8 mm
Glass th. 8 mm
Verre ép. 8 mm



Fuori misura:
altezza max 220 cm / larghezza max 120 cm
Out of standard:
height max. 220 cm / width max. 120 cm
Sur demande:
hauteur max. 220 cm / largeur max. 120 cm

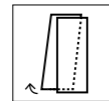

Sgancio rapido della porta
Door with quickrelease system
Décrochage rapide de la porte



Regolazione inclinazione porta
Inclination door adjustment
Réglage inclinaison de la porte



Sistema Soft-Close silenzioso di serie
Silent Soft-Close system as standard
Système silencieux Soft-Close de série

Configurazioni:
Configurations:
Configurations:

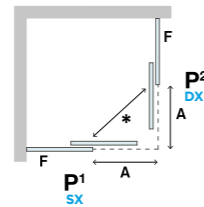

VERSIONE SX /DX
Left / Right
Gauche / Droite

Trattamento anticalcare:
Glass treatment:
Traitement verre:



Incluso nel prezzo
Included in the price
compris dans le prix

MAGGIORAZIONI / SURCHARGES / SUPPLÉMENTS

Fuori Misura:
Out of standard:
Sur mesure:



(richiedere fattibilità)
(ask for feasibility)
(vérifier la faisabilité avec le service technique)

Vetro con serigrafie:
Serigraphies (see page 95):
Sérigraphies (voir page 95):



maggiorazione dal TRASPARENTE
increase on the TRASPARENTE price
à appliquer sur le prix du TRASPARENTE

VENTO SCORREVOLE

Angolo
Corner
Coin

2 porte scorrevoli
2 sliding door
2 portes coulissantes



ATTENZIONE
Specificare il verso al momento dell'ordine.

ATTENTION
Indicate the side in the order.

ATTENTION
Indiquer le vers dans la commande.

P1 / P2 - PORTA SCORREVOLE / SLIDING DOOR / PORTE COULISSANTE

ART. ITEM ART.	ESTENSIBILITÀ EXTENSIBILITY EXTENSIBILITÉ	PIATTO TRAY RECEVEUR	APERTURA OPENING ENTRÉE	FISSO FIXED FIXE	PROFILO / PROFILE / PROFIL					
					BRILL / NERO	INOX / ORO / RAME	COLORATO			
					VETRI / GLASS / VERRE					
					○	●	○	●	○	●
D8SA800	67,5 - 69,5	70	23	29						
D8SA805	72,5 - 74,5	75	28	34						
D8SA810	77,5 - 79,5	80	31	39						
D8SA815	82,5 - 84,5	85	31	44						
D8SA820	87,5 - 89,5	90	36	44						
D8SA825	92,5 - 94,5	95	36	49						
D8SA830	97,5 - 99,5	100	41	49						
D8SA835	102,5 - 104,5	105	41	54						
D8SA840	107,5 - 109,5	110	44	56						
D8SA845	112,5 - 114,5	115	44	61						
D8SA850	117,5 - 119,5	120	50	56						

VETRI / GLASS / VERRE

○ TRASPARENTE

● BRONZO | SATINATO | GRIGIO EUROPA

ATTENZIONE!

Per il calcolo del prezzo totale vanno sommati 2 lati.

ATTENTION!

The total price is given by the addition of 2 sides.

ATTENTION!

Le prix total est donné par l'addition des 2 côtés.

DIMENSIONI APERTURA (*):
ENTRANCE DIMENSIONS (*):
DIMENSIONS DE PASSAGE (*):

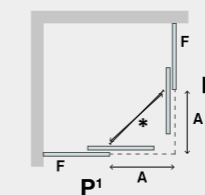

	70	75	80	85	90	95	100	105	110	115	120
70	33	37	39	43	48	50	56				
75	37	40	42	46	50	53	58				
80	39	42	44	48	52	54	59				
85											
90	43	46	48	51	55	57	62				
95											
100	48	50	52	55	58	61	65				